



MULTILIN

GET-8048A

GE Power Management

Relay Selection Guide



**Table
of
Contents**

INTRODUCTION

Page

Introduction	1
Basic Concepts	2
Types of Distress	3
Detection Modes	4
Protection Characteristics	5

PROTECTIVE ZONE PACKAGES

Generators	10
Motors	15
Feeders	20
Transformers	24
Buses	27
Incoming Lines	31
GE Relay Index	35
References	36

INTRODUCTION

Power distribution systems serving industrial or commercial facilities represent a variety of costs to the owner. Obviously, the capital cost of the equipment is a concern, as is the cost of the energy which that power system delivers to the loads which convert electrical energy to a saleable product or service. There are some less obvious costs - the cost or reliability, measured in products or services which cannot be sold because power is unavailable, or an even more illusive concept, the cost of quality, which relates to customer satisfaction. Ultimately, as the designer of the system struggles with devising a system arrangement and choosing equipment, he must face the reality that no matter how clever he is, no matter how much redundancy he builds into the system, and no matter how much he pays for premium quality components, he simply cannot build a system which will never fail.

This is where system protection, and protective relays become important. If component failure is inevitable, then it is necessary to provide a means of detecting these failures. Better and faster protection afford a number of desirable attributes, all of which ultimately result in saving the owner of the system money through cost avoidance. When component distress is detected and corrected earlier, the damage associated with the failure is minimized, which results in lower repair costs (or even the ability to repair versus the need to replace). At the same time, faster and more sensitive detection of problems means that the cause of the problem can be corrected while it is still a minor problem, and before it escalates into a major catastrophe.

Protection is applied on a component basis. Relays are associated with each major component of the power distribution system to detect various forms of distress associated with those components. If one of those relays operates (which means that an output contact closes because the relay detects a level of distress in excess of its calibration or setting), it initiates tripping of circuit breakers or other protective devices which then isolates the defective system components. It may be convenient to think of the circuit breaker as the muscle that does the work of isolating the component, while the relay is the brain which decides that isolation is required.

Because protection is associated with components, it has become customary to talk about relays which “protect” the component with which they are paired. While it is true that faster and more sensitive protection does reduce the amount of damage at the point of the actual fault or distress, and in this sense, relays which detect and de-energize defective equipment do protect their associated components, the value of relay protection on system continuity is even greater. In the limit, a failed motor may have to be replaced, but good relaying on the motor will isolate the motor from the remainder of the power distribution system, allowing it to continue to function and permitting the facility to continue in-service. Ultimately, therefore, it is system protection and service continuity that are the justification for good relay protection.

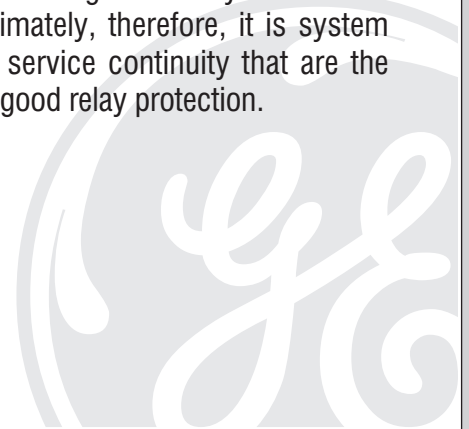

BASIC CONCEPTS

Zones of Protection

One of the most powerful conceptual tools available to the protection engineer is the notion of “zones” as shown in **Figure 1**. Rather than thinking of the power distribution system as unbounded, successful protection relies on visualizing the system as a collection of discrete zones which can be individually protected using equipment designed to detect the unique forms of abnormalities associated with each component.

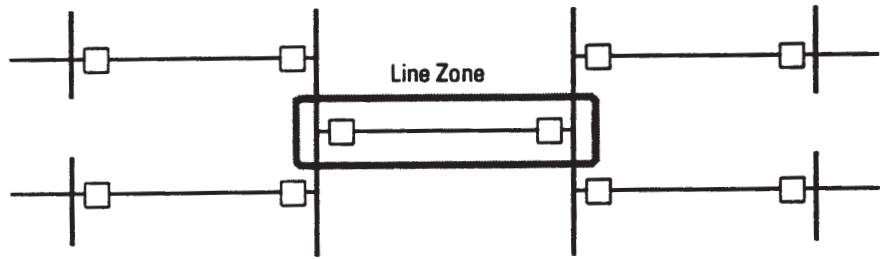

Figure 1
Zones include any circuit breakers associated with protected equipment

- Association with a significant component (in this case, a line).
- Terminates at and includes a circuit breaker (or other interrupter) which can respond to trip signals from relays associated with the zone.
- Represents a minimum amount of system which must be de-energized to correct a problem anywhere in the zone.

Other zones could be defined to comprise buses, generators, motors, cables, etc. **Figure 2** shows one final requirement about these zones - they must overlap. Because protection is applied in association with these defined zones, it is absolutely essential that every portion of the system must fall within a zone in order to assure that there are no areas which are unprotected.

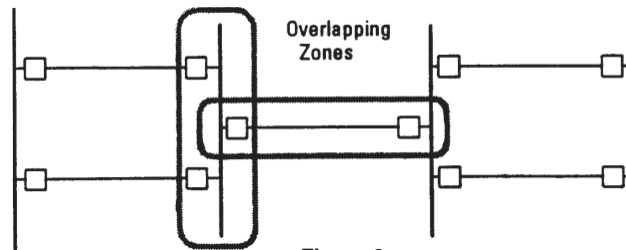

Figure 2
Zones must overlap

Primary and Backup Zones

In spite of the best efforts of system designers and protection specialists, and despite the fact that relays have a historical record of being among the most reliability components of the power system, the unexpected will happen. This has led to the practice of assuring that failure of a single relay can never result in loss of protection. This so-called “backup” can exist in any of several forms:

Remote Backup - in which the relays of one zone have the ability to also detect problems in adjacent zones.

Remote backup protection is the most common practice in both industrial and commercial applications, and usually involves time delays to assure selectivity.

Local Backup - in which each zone is equipped with a complete set of redundant relays. Often the relays which are designated as backup employ different measuring principles, and in more conservative schemes, may employ totally different signal sources, and even trip different breakers using different battery supplies.

TYPES OF DISTRESS

Overcurrent

Overcurrent is the term employed in the National Electrical Code to mean "short-circuit". On a healthy system, the flow of current is a function of the magnitude of electrical load. A short-circuit is a breakdown in insulation which results in an abnormal flow of current limited only by the impedance of the electrical distribution system. The distress associated with a short-circuit comes about because of the flash and arcing at the fault point, the depression in system voltage associated with the fault, and the thermal stress imposed on the conductors which must carry fault current. Short-circuits are the focus of greatest attention in protection of medium and high voltage systems.

The change in state from load current to short-circuit current occurs rapidly. From fundamental physics, it is known that the magnitude of current in an inductor cannot change instantaneously. This conflict can be resolved by considering the short-circuit current to consist of two components, a symmetrical ac current having the higher magnitude of the short-circuit current, and an offsetting dc transient which has an initial magnitude equal to the initial value of the ac current and which decays rapidly. The initial magnitude of the dc transient is directly controlled by the point on the voltage wave at which the short-circuit

occurs; if the short-circuit occurs at the natural zero crossing of the driving voltage sinusoid, the transient is maximized where as it is a minimum if the fault occurs at the crest of the voltage sinusoid. At any subsequent point in time, the magnitude of the dc transient is determined by the time constant of the decay of the dc which is controlled by the ratio of reactance to resistance in the impedance limiting the fault. For the protection engineer, the worst case initial current is that which includes the full dc transient.

The voltage which drives a short-circuit includes sources such as remote generators with voltage regulators that will maintain their value regardless of the presence of a short-circuit on the system, as well as nearby sources whose voltage will decay when the short-circuit is present. The amount of decay is determined by the nature of the source. Nearby generators and synchronous motors which have active excitation systems will sustain some voltage, but since the short-circuit will cause their terminal voltage to drop, the current they produce will gradually be reduced as the fault is allowed to persist. At the same time, induction motors will initially participate as short-circuit current sources, but their voltages will decay rapidly as the trapped flux is rapidly drained.

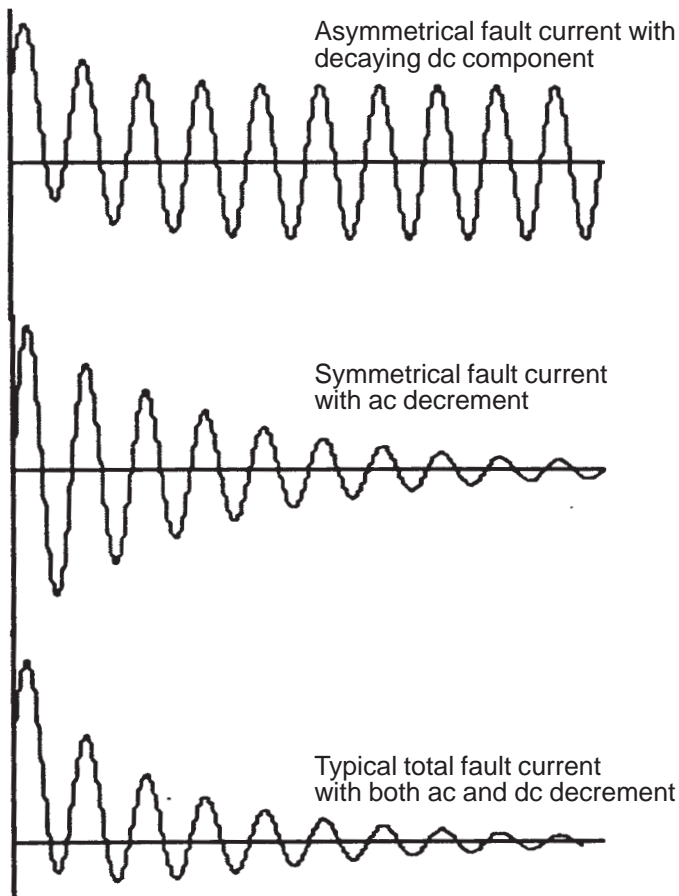

Figure 3

Short-circuit currents include components with both ac and dc decrement

Figure 3 illustrates how the various elements of asymmetry combine to create the most realistic case of the decaying symmetrical ac current combined with the decaying dc transient. From this figure, it is possible to describe a generalized short-circuit current in the following terms:

- High initial magnitude dc transient component of current which decays fairly rapidly with time.
- High initial magnitude symmetrical ac current which diminishes gradually with time.
- Symmetrical ac current lags driving voltage by a significant angle, approaching 90°.

Overload

Overload is exactly what the term implies - excessive load demand reflected back into the power distribution system. The undesirable aspect of overload is purely thermal (I^2t) heating in conductors and transformers, related thermal

abuse to the power utilization equipment which interfaces the load to the electrical system. Overload is a significant aspect of low voltage protection, but is usually not a major consideration at medium and high voltages.

Open Circuit

The power distribution system can tolerate open circuits continuously without harm. Where open circuits are a concern is on rotating machines - motors and generators - where they translate into abnormal rotor heating for which

these equipments have little tolerance. Hence, open circuit protection is frequently applied on motors and generators, and seldom on the passive portions of the distribution system.

Abnormal Voltage or Frequency

Abnormal voltage or frequency usually is a consequence of some form of overall system distress, and while these symptoms may appear following failure of a power distribution system component, this is usually indicative of some undesirable consequence of that system failure rather

than a direct result of the failure itself. Undervoltage can result in overload-like thermal heating, while overvoltage can shorten insulation life and accelerate insulation failure (and short-circuits). Abnormal frequency usually is indicative of an imbalance between load and generation.

DETECTION MODES

Circuit - Current or Impedance

Based on the desire to array protection in logical zones, the most common mode of protection is one which can not only detect that an abnormality (such as a short circuit) exists, but which can also determine its location. The parameter which most simply locates faults is current - short-circuits result in abnormal flow of current, and a relay system which looks for high current will be able to selectively detect faults. Current is the parameter which is used in the vast majority of all protection schemes, and is used almost exclusively from 35kV down through 120V residential distribution.

Closely related to current detection is measurement of apparent impedance. Apparent impedance is the ratio of voltage to current measured at a relay location and is a direct measure of the electrical separation between the relay location and a point on the system where the voltage is depressed to zero by a short-circuit. Impedance measurement is more complicated than current measurement, and hence its use is reserved for more critical applications at the higher voltages, typically above 69 kV.

System - Voltage or Frequency

Voltage measurements can be used to detect that something unusual is happening on the system, but generally voltage will not give any indication of the location

of the problem. Hence, measurement of voltage is usually reserved for overall system protection functions. Likewise, frequency is an overall system issue.

PROTECTION CHARACTERISTICS

Time Overcurrent

Time overcurrent protection is the predominant form of protective relaying in medium voltage industrial and commercial power systems. This form of protection employs relays with inverse time-current characteristics; that is, operating time of these relays becomes less as the current magnitude increases. The basic operating characteristics trace their heritage to the natural operating characteristics of the induction disk overcurrent relay, and as a result static analog and digital relays are designed to emulate this basic characteristic, but there is also a noble rationale for the inverse-time relationship. Relays are intended to detect and initiate tripping of high-magnitude fault currents quickly enough to avoid thermal damage to conductors, and the natural heating characteristic is also an inverse-time relationship.

Traditionally, the characteristics of time overcurrent relays has been published in the form of graphical curves showing the dependent variable (operating time) on the vertical axis and the independent variable (operating current) on the horizontal axis. It is also a tradition that these curves are plotted on a special log-log paper. These traditions trace their origin to the manual practices involved in determining settings for relays.

There are a number of characteristics in common use, which are shown in **Figure 4**. Each of these exists to address specific application needs. Following is a list of the most common characteristics together with their usual applications and also the code number which GE uses to identify each curve shape:

Inverse medium time (51) - best suited for applications where the variations in the magnitude of fault current are related primarily to switching of sources on the system, such as in paper mill systems with a number of small hydroelectric generators which are switched on and off depending on water conditions.

Very inverse medium time (53) - best suited for general applications where the variations in the magnitude of fault current are primarily determined by system impedance and fault location. This relay characteristic is the best choice for most industrial and commercial applications.

Inverse medium-long time (57) - best suited for applications as backup ground fault protection on complex low-resistance grounded medium voltage systems.

Inverse long time (66) - best suited for overload and locked rotor protection of motors.

Extremely inverse medium time (77) - best suited for application on utility residential distribution circuits where selectivity with distribution fuse cutouts and reclosers is a requirement, and where "cold load pickup" is a consideration.

Inverse short time (95) - best suited for backup ground fault protection applications on solidly grounded low voltage systems where the feeders have instantaneous ground fault protection.

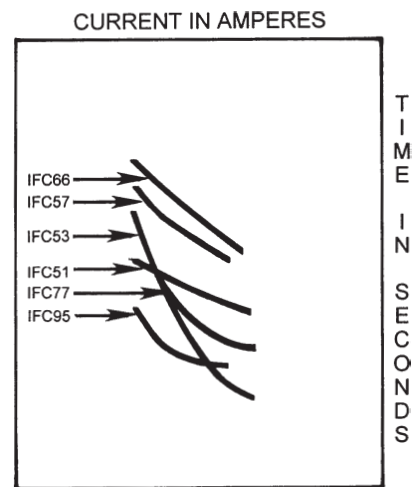

Figure 4

Inverse time characteristics of various GE time overcurrent relay models

The principle of time overcurrent protection is that relays are applied appropriately at the terminals of zones, and each relay is then given both a current pickup and a time delay setting. The current pickup establishes the sensitivity of the relay; a variety of "rules" dictate what this sensitivity must be. Some of these rules are mandatory and must be followed; the National Electrical Code contains a number of requirements on the current setting of overcurrent relays. Other rules are embodied in application standards, and while these are not absolutely mandatory, they do represent a consensus of the industry from which most engineers would not want to deviate. Finally, there are several "rules of thumb", or conventional practices which, through experience, have been recognized as good things to do.

The time setting is used to achieve selective backup protection. How this happens is best illustrated with characteristic curves as in **Figure 5**. For a fault on a feeder, the current magnitude determines the operating time of all relays. Relays which are closest to the fault have time settings which result in faster operation than those which are further away. Therefore, the primary relays which are closest to the fault want to trip first while the more remote backup relays wait, but if the primary relays (or their associated circuit breakers) fail, then the backup relays time out and trip. The time margin between the settings of these relays must take into account three factors:

- The operating time of the circuit breakers. Modern medium voltage breakers are rated for 5 cycle interrupting time, and the time allowance is traditionally 0.1 second.
- Overtravel, which is the tendency for a relay to continue to time after the fault current is interrupted by a downstream circuit breakers. Overtravel is a natural characteristic of the inertia of electromechanical induction disk relays, and while exact values vary widely, the traditional allowance is 0.1 seconds. Most static analog and digital relays are designed to have no practical overtravel. If the backup relay has an overtravel tendency, it's time delay must be long enough to account for that overtravel.
- Margin to account for imponderables such as the uncertainties in the magnitude of fault current, inaccuracies in instrument transformers, manufacturing and calibration variations in relays, etc. The amount of margin allowed depends upon how much risk the relay engineer is willing to assume; typical values range from 0.1 to 0.3 seconds.

The total “coordinating time margin” is the sum of these three factors and ranges from 0.2 to 0.5 seconds; a 0.3 second margin is often taken as a reasonable compromise between the objectives of speed and security.

The chore of determining settings for an array of time overcurrent relays is time consuming work which entails making a number of engineering judgments. One must start closest to the load and work toward the sources in the system, determining both pickup current and time delays settings for each relay in succession. It is not unusual to find that this process results in excessively long relay operating times for faults near the source, so it is then necessary to work back through the system making other judgments and introducing compromises. It has been correctly said that this task is the most difficult and exacting work within the province of the relay engineer. The traditional approach entailed tracing relay performance curves, but the availability of computer tools eliminate some of this drudgery. However, even with this automation, one must still be prepared to focus carefully on the task at hand and be prepared to deal with exacting details.

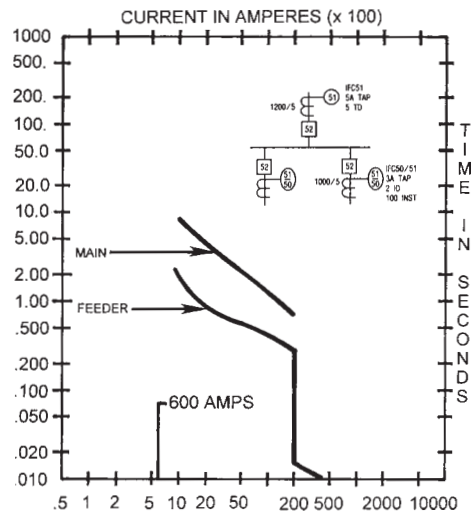

Figure 5

Selective coordination of time overcurrent relays assumes that the backup relay will always be slower than the primary relay

Voltage

Voltage protection tends to be applied to detect various forms of overall system distress. The actual detection functions can be either undervoltage (which operate in response to an undesirable reduction in voltage) or overvoltage (which respond to high voltage). One of the application challenges in working with undervoltage or overvoltage relays is that normal system voltage encompasses a range of magnitudes around the nominal rated value. Furthermore, there are normal system conditions which produce momentary excursions outside this band of values. As a result, the relays used to provide this function may be either instantaneous or time-delayed, and in the case of

time, the delay function may be either inverse time or definite time.

The use of inverse time delay is probably more of a tradition traceable to the historical use of the induction disk technology than it is something which is required by the application. The one situation where an inverse time delay is desirable is when a time-delayed undervoltage relay on a bus must be selective with an inverse time overcurrent relay on a feeder in response to system faults. Note that while this application is possible, it is not easy to actually do.

Directionality

Many simple applications can be satisfied by relays which measure only magnitude (of current) and time duration. However, to achieve fast, secure, selective operation in "network" systems which involve parallel paths between sources and loads, or systems with multiple sources of fault current, the relays will also be required to determine the direction of current flow. The basic principle used in determining directionality is that, in a power system operating at unity power factor, phase current and phase-to-neutral voltage are in phase, and that phase current leads the phase-to-phase voltage between the other two conductors by 90° **Figure 6**. Fault current in that conductor lags its phase-to-neutral voltage by the angle of system impedance, θ . Therefore, the phase angle of fault current in Phase A will always lead the angle of the B-C voltage by an angle which can never exceed 90° . However, if the direction of the current in Phase A reverses, then its' angle will lag the B-C voltage by up to 90° .

Figure 7 shows a relay characteristic which utilizes this concept to determine directionality of fault current.

A directional relay on Phase A uses the B-C voltage as its polarizing reference, and together they establish a directional phasor which leads the B-C reference voltage by an angle τ which is fixed in the design of the relay. Operation can occur if the current angle falls within 90° of the angle of the directional phasor.

In most instances, directionality is a function which is added to other relay characteristics. That is, overcurrent relays are made directional by incorporating a directionality function to the design of the relay such that an overcurrent measurement can only be made if the directionality is satisfactory.

With induction relays, one induction unit is required for the overcurrent measurement, while a separate unit is used to determine the direction of the current. Digital relays are less complex; the directional function may be a few more lines of code.

Normal current leads voltage by 90°

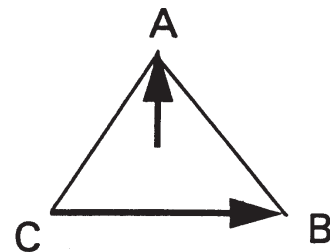

Figure 6

Basic system phasor relationships

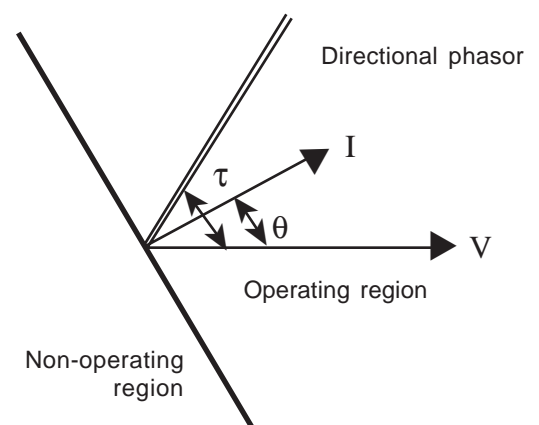

Figure 7

Directional relay directionality

Distance

The most complex relays in common application are called distance relays because they measure the apparent impedance between the relay and the short-circuit. The apparent impedance is measured by computing the ratio between voltage and current at the relay. These relays, which are almost always directional, are typically employed on transmission lines where impedance is both predictable and constant. In these applications, impedance is directly proportional to physical distance. In fact, modern digital distance relays have the ability to actually report this distance as an aid to locating the point of fault. They are also commonly used for generator protection, and in special applications on motors.

Distance relay applications are very different from overcurrent applications; selectivity is achieved by means of sensitivity (distance setting) and time delay, but the timing functions are almost always definite time rather than inverse time. A more dramatic difference is that distance relay application technology has its own "language", the R-X diagram as shown in **Figure 8**.

The R-X diagram is a set of coordinates of impedance where the origin is at the relay location and impedances in the first quadrant are in the designated tripping direction of the impedance-measuring relays. Impedances in the third quadrant represent short-circuits in the non-tripping direction, while second and fourth quadrant impedances are dynamic characteristics which are beyond the depth of this text.

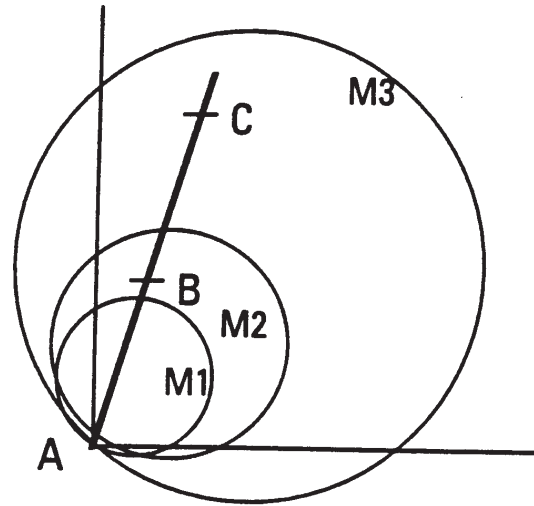

Figure 8

Distance relay characteristic shown on an R-X diagram

Differential

While overcurrent, voltage, distance and directionality are powerful techniques, all of them involve some compromise between the objectives of reliability, security, speed, selectivity and economy. Differential protection is different. It is profoundly simple, inherently secure, highly reliable, fast, and reasonably economical. As a result, differential protection is the most important concept in protection.

The concept is a direct extension of Kirchoff's current law - the sum of all currents into a region must be zero. Current transformers are placed at each electrical terminal of the protected zone and wired together as indicated in **Figure 9**. For external faults, where fault current passes through the zone, current circulates in the current transformer secondaries without passing through the relay. If the fault is internal to the zone, then the currents introduced into the current transformer secondaries oppose each other and are forced to flow through the relay.

The basics of a differential application include:

- CT at each power connection to the protected zone
- All ct's have the same rating
- Careful attention to assure proper ct connections
- Differential protection is primary protection: it cannot provide backup protection for remote zones

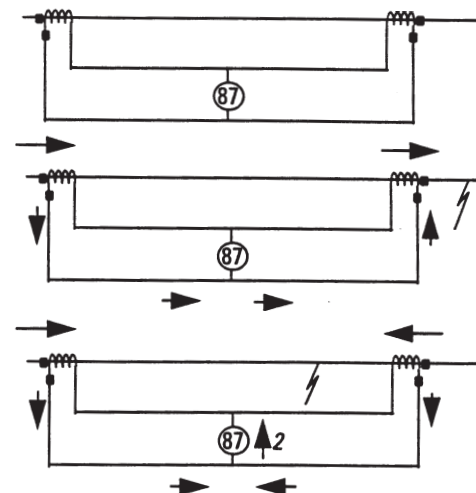

Figure 9

Basic operation of differential relays

PROTECTION PACKAGES

The following protection packages are organized according to the types of equipment generally encountered in medium voltage systems. Generators, Motors, Feeders, Transformers, Buses, and Incoming Lines will be addressed.

Packages are based on commonly used power system configurations. Other considerations may be needed if unique power system arrangements are used.

GEN GENERATOR

Protective Zone (GEN1)

Minimum protection for a small machine with low resistance grounding:

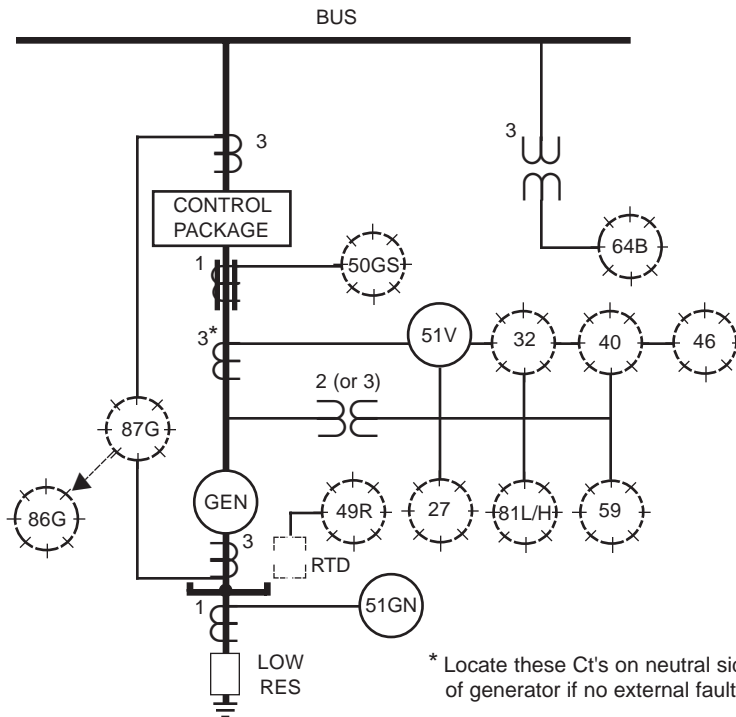

Device list for GEN 1

27	Undervoltage
32	Power Direction
40	Loss of Excitation
46	Current Unbalance
49R	Overload (RTD)
50GS	Instantaneous Overcurrent Ground
51GN	Time Overcurrent Ground
51V	Time Overcurrent (V Restraint)
59	Overvoltage
64B	Bus Ground Detection
81L/H	Frequency
86G	Lockout Auxiliary
87G	Differential

Qty.	Device No.	Description	GE Model No.
Basic Package			
3	51V	Voltage-restrained Time Overcurrent Relay	IFCV51AD
1	51GN	Neutral Ground Overcurrent Relay	DIFC or IFC53A
Options			
1	27	Undervoltage Relay	TOV5 or IAV54
1	32	Reverse Power Relay (detects losses over 5%) or Reverse Power Relay (detects losses below 5%)	ICW51A or GGP53C
1	40	Loss-of-excitation Relay	CEH51A
1	46	Negative Sequence Relay	SGC21C
1	49R	Stator Overtemperature Relay (RTD input)	IRT51E
1	50GS	Ground Sensor Overcurrent Relay (in place of 51GN where system ground is not generator neutral)	DIFC or HFC21
3	51VC	Voltage-controlled Overcurrent Relay (in place of 51V)	IFCS51AD
1	59	Overvoltage Relay	TOV5 or IFV71AD
1	64B	Generator Ground Overvoltage Relay (in place of 51GN where generator is ungrounded)	TOV5 or IFV51DD
1	81 L/H	Under/Overfrequency Relay	SFF202B
1	86G	Lockout Auxiliary Relay	HEA61
1	87G	Self-balancing Current Differential Relay (for connections see MTR1A figure) or Percentage Current Differential Relay	MDP or CFD22A

GEN GENERATOR

Protective Zone (GEN1A)

Alternate protection for a small machine with low resistance grounding:

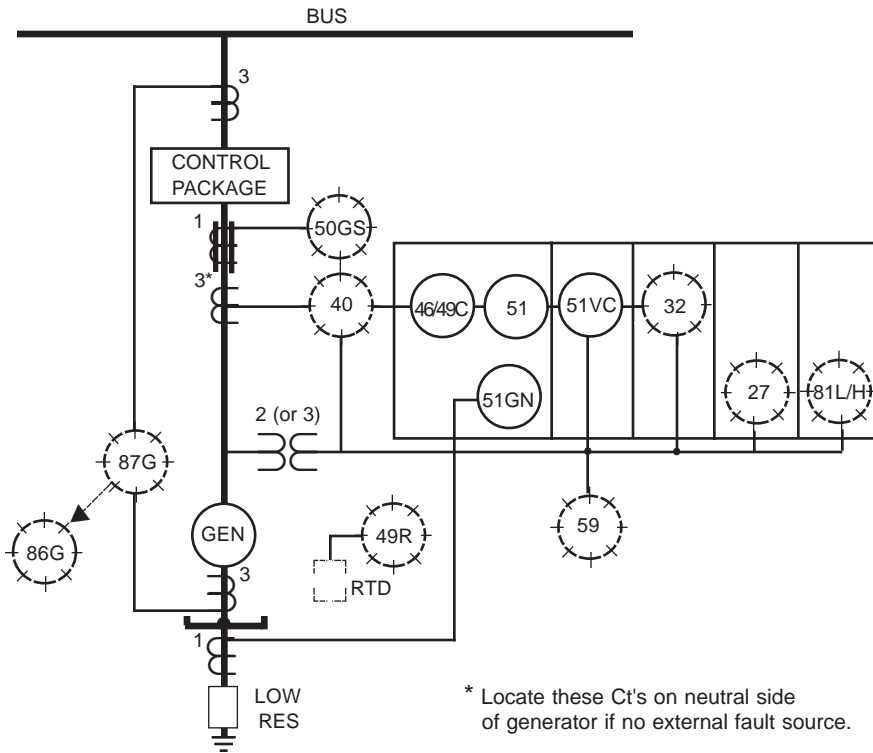

Device list for GEN 1A

27	Undervoltage
32	Power Direction
40	Loss of Excitation
46	Current Unbalance
49R	Overload (RTD)
50GS	Instantaneous Overcurrent Ground
51GN	Time Overcurrent (Ground)
51VC	Time Overcurrent (V Control)
59	Oversvoltage
81L/H	Frequency
86G	Lockout Auxiliary
87G	Differential

Qty.	Device No.	Description	GE Model No.
1		Alternate Package	
		Multifunction analog relay system containing the following modules:	MID100
		Multifunction Module with functions:	MGC
	46	Negative Sequence	
	49C	Thermal Image	
	51	Definite Time Overcurrent	
	51GN	Neutral Ground Overcurrent	
	51VC	Voltage-controlled Overcurrent Modules	MIC7/TOV4
		Options	
1	27	Undervoltage Module (into MID100 system)	TOV5
1	32	Reverse Power Module (into MID100 system)	TCW
1	81L/H	Under/Overfrequency Module (into MID100 system)	MFF

(For additional options, see GEN1 package)

GEN GENERATOR

Protective Zone (GEN2)

Recommended protection for a small machine with low/high resistance grounding:

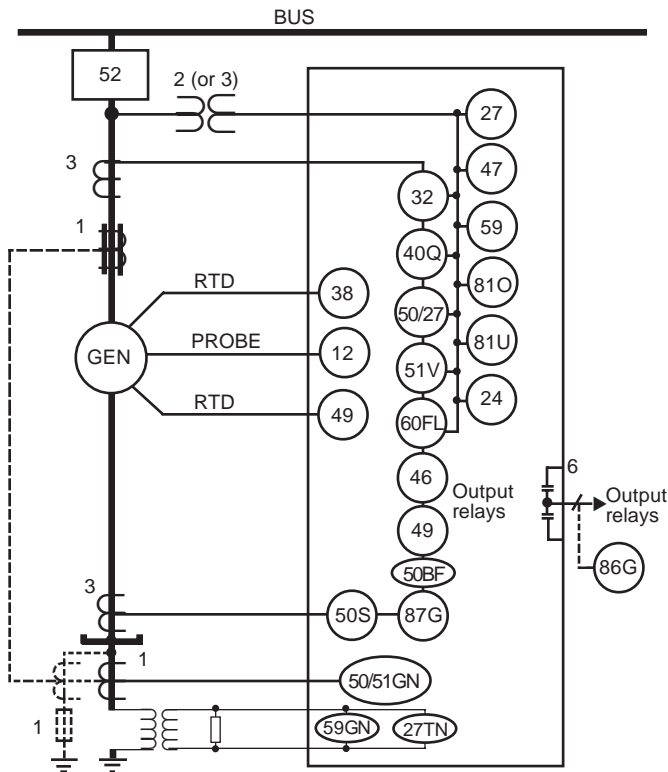

Device list for GEN 2

12	Overspeed
24	Overexcitation, Volts/Hz
27	Undervoltage
50/27	Inadvertent generator energization
32	Reverse power for anti-motoring
38	Bearing overtemperature
39	Bearing vibration (analog inputs)
40Q	Loss of field
46	Negative Sequence Overcurrent (I_2^2t)
47	Voltage phase reversal
49	Stator thermal (RTD and thermal model)
50BF	Breaker failure detection
50S	Instantaneous overcurrent (during startup)
50/51GN	Instantaneous or definite time overcurrent
51V	Voltage restrained phase overcurrent
59	Overvoltage
59GN/27TN	100% stator ground
60FL	VT fuse failure detection
81	Over and underfrequency
87G	Phase differential
86G	Lockout Auxiliary

Qty.	Device No.	Description	GE Model No.
1		Basic Package	
		Multifunction microprocessor-based protection including the following functions:	SR489
	12	Overspeed	
	24	Overexcitation, Volts/Hz	
	27	Undervoltage	
	50/27	Inadvertent generator energization	
	32	Reverse power for anti-motoring	
	38	Bearing overtemperature	
	39	Bearing vibration (analog inputs)	
	40Q	Loss of field	
	46	Negative Sequence Overcurrent (I_2^2t)	
	47	Voltage phase reversal	
	49	Stator thermal (RTD and thermal model)	
	50BF	Breaker failure detection	
	50S	Instantaneous overcurrent (during startup)	
	50/51GN	Instantaneous or definite time overcurrent	
	51V	Voltage restrained phase overcurrent	
	59	Overvoltage	
	59GN/27TN	100% stator ground	
	60FL	VT fuse failure detection	
	81	Over and underfrequency	
	87G	Phase differential	
		Sequential tripping logic	
		Trip coil supervision	
		Options	
1	86G	Lockout Relay	HEA61
		(For additional options, see GEN1 package)	

MTR MOTOR

Protective Zone (MTR1)

Minimum protection for a small induction motor (below 1500HP):

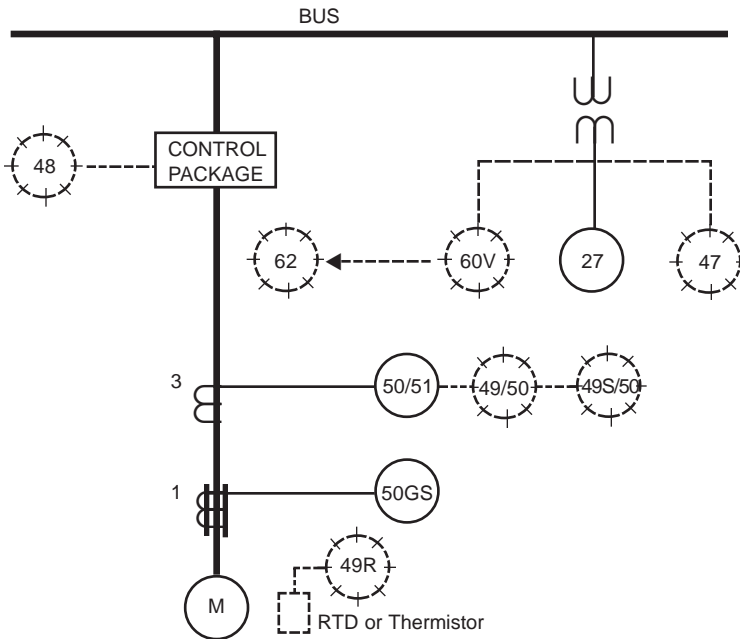

Device list for MTR1

27	Time Undervoltage
47	Undervoltage and reverse phase sequence
48	Incomplete sequence timer
49/50	Thermal overcurrent
49R	Winding overtemperature (RTD)
49S/50	Time and instantaneous overcurrent (locked rotor)
50GS	Instantaneous overcurrent ground
50/51	Time and instantaneous overcurrent
60V	Voltage unbalance
62	Timer

Qty.	Device No.	Description	GE Model No.
Basic Package (Multiphase Overcurrent)			
1	27	Undervoltage Relay	IAV54E or TOV5
1	50/51/50GS	Overload, Short Circuit and Ground Fault Relay	MDP0 or 735
First Alternate Package (Single Phase Overcurrent)			
1	27	Undervoltage Relay	IAV54E or TOV5
3	50/51	Overload and Short Circuit Relay	IFC66B or DIFC
1	50GS	Ground Fault Relay	HFC21 or DIFC
Second Alternate Package (Multiphase Overload)			
1	27	Undervoltage Relay	IAV54E or TOV5
1		Microprocessor-based Motor Relay including the following functions:	P4A
	46	Unbalance or Current-Reversal	
	49	Overload	
	49R	Winding Overtemperature	
	50GS	Ground Fault	
	66	Successive Starts Protection	
Options			
1	38	Bearing Overtemperature Relay (RTD)	IRT51E
1	47	Three-phase Undervoltage and Reverse Phase Sequence Relay (in place of 27) (Requires open-delta or wye-wye voltage transformers)	ICR
1	48	Adjustable Time Delay Relay or Timer	_____
1	49R	Winding Overtemperature Relay	IRT51E
1	49S/50	Stalled Rotor Relay	IFC66K
1	60V	Voltage Unbalance Relay (use with 62 and may require harmonic filter)	NBV11
1	62	Timing Auxiliary Relay	SAM201

MTR MOTOR

Protective Zone (MTR1A)

Recommended protection for a more important small inductions motor (below 1500 HP):

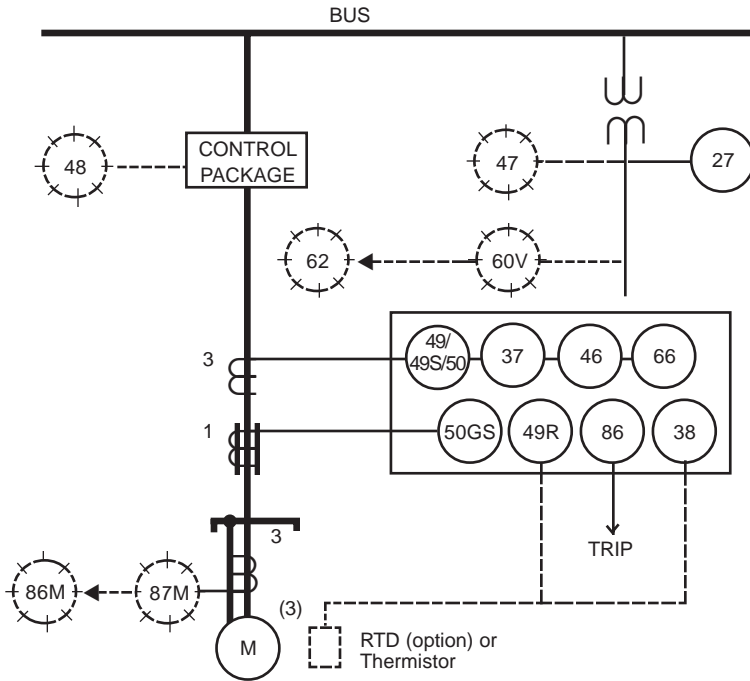

Device list for MTR1A

- 27 Undervoltage
- 37 Undercurrent
- 38 Bearing Overtemperature (RTD)
- 46 Unbalance or current-reversal
- 47 Three phase undervoltage and reverse phase sequence
- 48 Adjustable definite time device or timer
- 49 Overload
- 49R Winding Overtemperature (Thermistor or RTD)
- 49S Locked rotor
- 50 Short circuit
- 50GS Ground fault
- 60V Voltage unbalance
- 62 Timer
- 66 Successive starts
- 87M Differential
- 86,86M Lockout Auxiliary

Qty.	Device No.	Description	GE Model No.
1		Basic Package	
		Microprocessor-based Motor Relay including the following functions:	239 or MMC
	37	Undercurrent	
	38	Bearing Overtemperature (239 only)	
	46	Unbalance or Current-Reversal	
	49	Overload	
	49R	Winding Overtemperature (Thermistor or RTD) (239 only)	
	49S	Locked Rotor	
	50	Short Circuit	
	50GS	Ground Fault	
	66	Successive Starts	
	86	Lockout Relay (239 only)	
1	27	Undervoltage Relay	TOV5
		Options	
1	86M	Lockout Auxiliary Relay	HEA61
1	87M	Self-balance Differential Relay (Add if required and if possible to mount three 50/5A current transformers at the motor.) or Percentage Differential Relay (Add if required. See MTR2 figure for one-line representation) (For additional options see MTR1)	HFC23 CFD22A or DTP1

MTR MOTOR

Protective Zone (MTR2)

Minimum protection for a large induction motor (1500 HP and above):

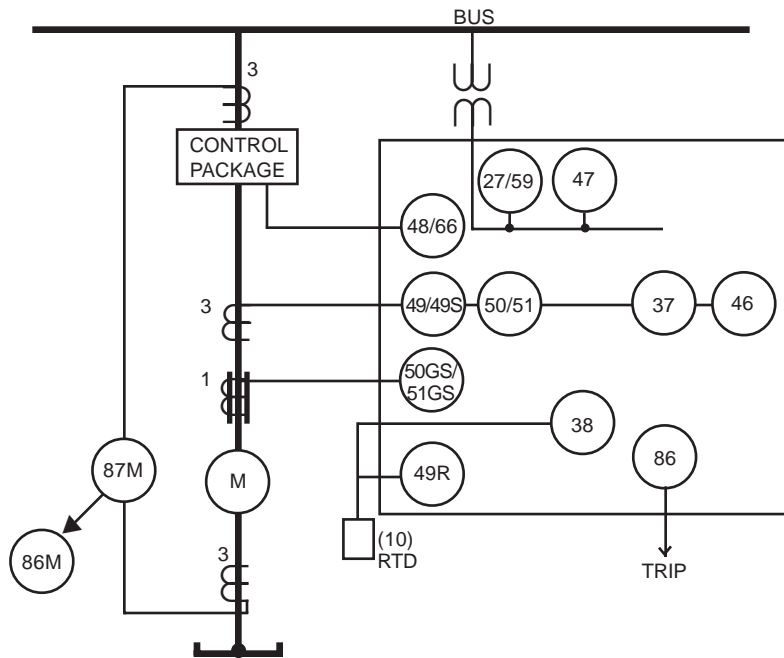

Device list for MTR2

27/59	Under and overvoltage
37	Undercurrent
38	Bearing Overtemperature (RTD)
46	Current unbalance
47	Undervoltage/reverse phase sequence
48	Incomplete sequence
49	Overload
49R	Winding overtemperature (RTD)
49S	Locked rotor protection
50/51	Instantaneous & time overcurrent
50GS/51GS	Instantaneous & time overcurrent ground sensor
66	Successive starts
86,86M	Lockout Auxiliary
87M	Differential

Qty.	Device No.	Description	GE Model No.
1		Basic Package	
		Digital Motor Relay including the following functions:	269 Plus
	27	Undervoltage (Meter Option)	
	37	Undercurrent	
	38	Bearing Overtemperature (RTD)	
	46	Current Unbalance	
	47	Voltage Phase Loss/Sequence (Meter Option)	
	48	Incomplete Sequence	
	49R	Winding Overtemperature	
	49S	Locked Rotor	
	49/51	Overload	
	50GS/51GS	Ground Fault	
	51R	Jam (Running)	
	59	Overvoltage (Meter Option)	
	66	Successive Starts	
	86	Lockout Relay	
1	87M	Differential Relay	CFD22A or DTP1
1	86M	Lockout Auxiliary Relay	HEA61

Options

(See options for MTR1 and MTR1A)

MTR MOTOR

Protective Zone (MTR2A)

Recommended protection for a more important large induction motor (1500 HP and above):

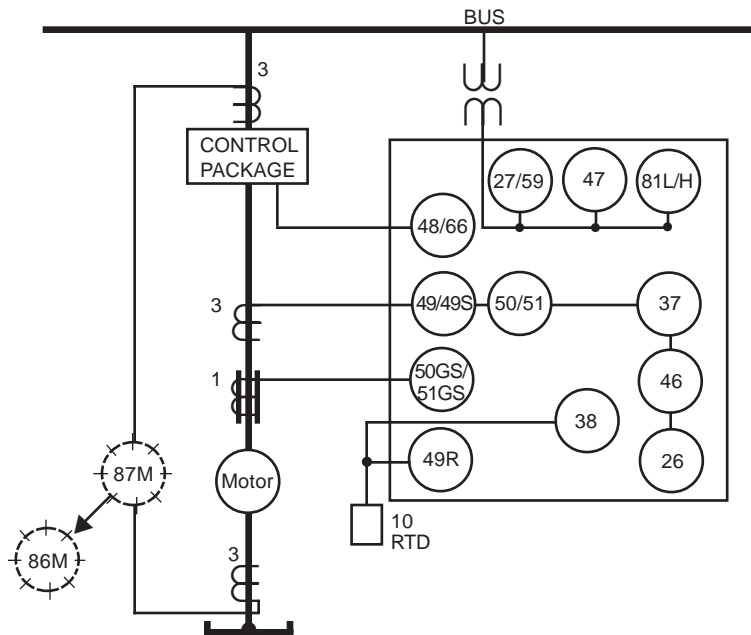

Device list for MTR2A

27/59	Under and overvoltage
37	Undercurrent
46	Current unbalance
47	Undervoltage/reverse phase sequence
48	Incomplete sequence
49	Overload
49R	Winding overtemperature (RTD)
49S	Locked rotor
50/51	Instantaneous and time overcurrent
50GS/51GS	Instantaneous and time overcurrent ground sensor
66	Successive starts
81L/H	Frequency
86M	Lockout Auxiliary
87M	Differential

Qty.	Device No.	Description	GE Model No.
1		Basic Package	
	27	Undervoltage	
	37	Undercurrent	
	38	Bearing Overtemperature (RTD)	
	46	Current Unbalance	
	47	Voltage Phase Loss/Sequence	
	48	Incomplete Sequence	
	49R	Winding Overtemperature	
	49S(26)	Locked Rotor	
	49/51	Overload	
	50	Short Circuit	
	50GS/51GS	Ground Fault	
	51R	Jam (Running)	
	59	Overvoltage	
	66	Successive Starts	
	81L/H	Under-and Overfrequency	
	87M	Self-Balance Differential (for connections see MTR1A figure)	
1	86M	Lock-out Auxiliary Relay	HEA61
		Options	
1	87M	Differential Relay	CFD22A or DTP1
		(See options for MTR1, and MTR1A)	

MTR MOTOR

Protective Zone (MTR3)

Recommended protection for a synchronous motor in addition to that provided in preceding zones MTR1 through MTR2A:

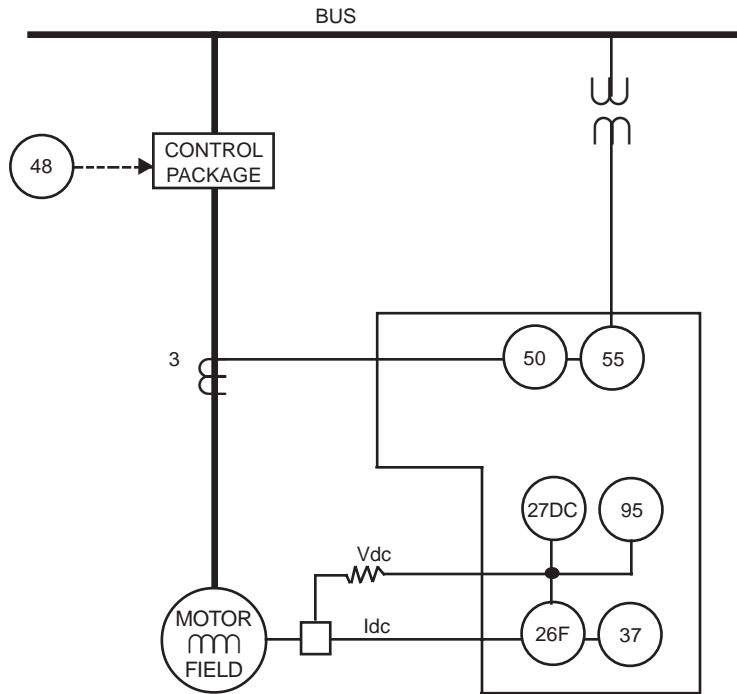

Device list for MTR3

26F	Winding Overtemperature
27DC	Undervoltage
37	Undercurrent
48	Incomplete sequence
50	Instantaneous overcurrent
55	Power factor
95	Reluctance Torque Sync/Re-Sync

Qty.	Device No.	Description	GE Model No.
1		Basic Package Microprocessor-based Synchronous Motor Relay including the following functions:	SPM
	26F	Ammortisseur Winding Overtemperature (Include if field is accessible)	
	27DC	Undervoltage Relay	
	37	Undercurrent	
	50	Short Circuit	
	55	Out of Step Protection/Power Factor	
	95	Reluctance Torque Synchronizing and Re-Synchronizing	
	96	Autoloading/Unloading Relay	

FDR FEEDER

Protective Zone (FDR1)

Standard Non-directional circuit, residually connected ground relay:

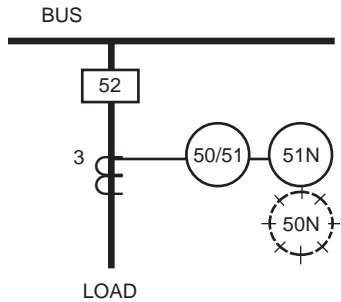

Device list for FDR1

50/51	Phase overcurrent and short circuit
51N	Time delay ground fault
50N	Instantaneous ground fault

Qty.	Device No.	Description	GE Model No.
Basic Package			
1	50/51/ 51N or 50N	Phase Overcurrent, Short Circuit and Ground Fault Relay	MDP or SR735
Alternate Package (Single Phase Units)			
3	50/51	Phase Overcurrent & Short Circuit Relay	DIFC or IFC53B
1	51N or 50N	Time Delay Ground Fault Relay Instantaneous Ground Fault Relay	DIFC or IFC53A DIFC or HFC21
Second Alternate Package			
1		Multifunction microprocessor-based relay system including the following functions:	DFP100 or DFP200 or SR750
	27	Undervoltage	
	46	Negative Sequence Overcurrent (DFP100 & 200 only)	
	47	Negative Sequence Voltage (SR750 only)	
	51	Phase Overcurrent	
	51N	Residual Overcurrent	
	59	Overvoltage	
	74LM	High Impedance Ground (DFP200 only)	
	79	Recloser	
	81L/H	Frequency	
Options			
1	79	Recloser Relay	SLR12

FDR FEEDER

Protective Zone (FDR2)

Standard Non-directional circuit, with ground sensor relay:

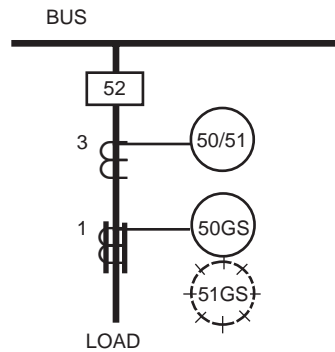

Device list for FDR2

50/51	Phase overcurrent and short circuit
50GS	Instantaneous ground fault
51GS	Time delay ground fault

Qty.	Device No.	Description	GE Model No.
Basic Package			
1	50/51/ 51GS or 50GS	Phase Overcurrent, Short Circuit and Ground Fault Relay	MDP / SR735
Alternate Package (Single Phase Units)			
3	50/51	Phase Overcurrent & Short Circuit Relay	IFC53B / DIFCA
1	51GS or 50GS	Time Delay Ground Fault Relay Instantaneous Ground Fault Relay	IFC53A / DIFCA HFC21
Second Alternate Package			
1		Multifunction microprocessor-based relay system including the following functions:	DFP100 or DFP200 or SR750
	27	Undervoltage	
	46	Negative Sequence Overcurrent (DFP100 & 200 only)	
	47	Negative Sequence Voltage (SR750 only)	
	51	Phase Overcurrent	
	51N	Residual Overcurrent	
	59	Overvoltage	
	74LM	High Impedance Ground (DFP200 only)	
	79	Recloser	
	81L/H	Frequency	
Options			
1	79	Recloser Relay	SLR12

FDR FEEDER

Protective Zone (FDR3)

Standard Directional circuit:

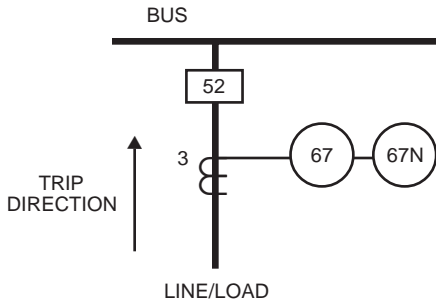

Device list for FDR3

- 67 Directional overcurrent and short circuit
- 67N Directional time delay and instantaneous ground fault

Qty.	Device No.	Description	GE Model No.
Basic Package			
1	67/67N	Directional Phase and Ground Fault Relay (Optional recloser 79 function is included).	DFP100 or SR750 / SR760
Alternate Package (Single Phase Units)			
3	67	Directional Overcurrent Relay	IBC53 or JBC53
1	67N	Directional Ground Fault Relay	IBCG53 or JBCG53
Options			
1	79	Recloser Relay	SLR12

FDR FEEDER

Protective Zone (FDR4)

Long lines and critical short length lines:

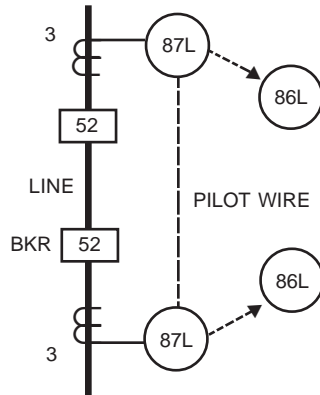

Device list for FDR4

87L Pilot wire line
86L Lockout auxiliary

Qty.	Device No.	Description	GE Model No.
Basic Package			
2	87L	Pilot Wire Line Differential Relay	SPD11
2	86L	Lockout Auxiliary Relay	HEA61
Options			
1	85LM	Pilot Wire Monitor Relay (sending end)	SPA11
1	85LM	Pilot Wire Monitor Relay (receiving end)	SPA12
Alternate Package			
2	87L	Current Differential Relay	DLS3
2	86L	Lockout Auxiliary Relay	HEA61

TR TRANSFORMER

Protective Zone (TR1)

Protection for transformers 2500KVA and below, medium and low voltage windings:

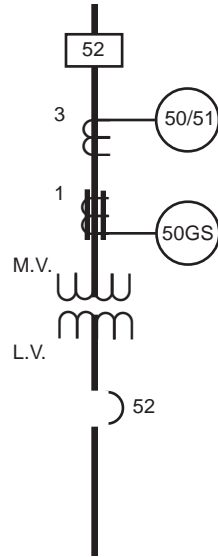

Device list for TR1

50/51 Overcurrent & short circuit
50GS Ground fault

Qty.	Device No.	Description	GE Model No.
Basic Package			
1	50/51/50GS	Overcurrent, Short Circuit and Ground Fault Relay	MDP or SR735
Alternate Package (Single Phase Units)			
3	50/51	Overcurrent and Short Circuit Relay	DIFC or IFC53B
1	50GS	Ground Fault Relay	DIFC or HFC21
Second Alternate Package			
1		Multifunction microprocessor-based relay system including the following functions:	DFP100 or DFP200 or SR750
	27	Undervoltage	
	46	Negative Sequence Overcurrent (DFP100 & 200 only)	
	47	Negative Sequence Voltage (SR750 only)	
	51	Phase Overcurrent	
	51N	Residual Overcurrent	
	59	Overvoltage	
	74LM	High Impedance Ground (DFP200 only)	
	81L/H	Frequency	

Protective Zone (TR2)

Protection for transformers 750kVa and above, medium voltage windings:

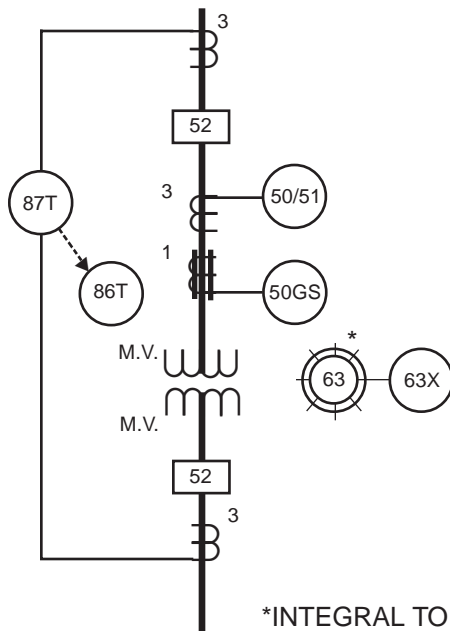

Device list for TR2

87T	Differential
86T	Lockout auxiliary
50/51	Overcurrent & short circuit
50GS	Ground fault
63	Integral fault pressure
63X	Fault pressure auxiliary

Qty.	Device No.	Description	GE Model No.
Basic Package			
1	87T	Differential Relay	DTP or SR745
	63X	Fault Pressure Auxiliary Relay	
X	86T	Lockout Auxiliary Relay (quantity as required)	HEA61
1	50/51/50GS*	Overcurrent, Short Circuit and Ground Fault Relay	MDP
Alternate Package (Single Phase Units)			
3	87T	Differential Relay	STD15C or BDD15B
X	86T	Lockout Auxiliary Relay (quantity as required)	HEA61
3	50/51	Overcurrent and Short Circuit Relay	IFC53B
1	50GS	Ground Fault Relay	HFC21
1	63X	Fault Pressure Auxiliary Relay	HAA16B

*Note: The SR745 relay includes these functions.

Additional Transformer Ground Protection

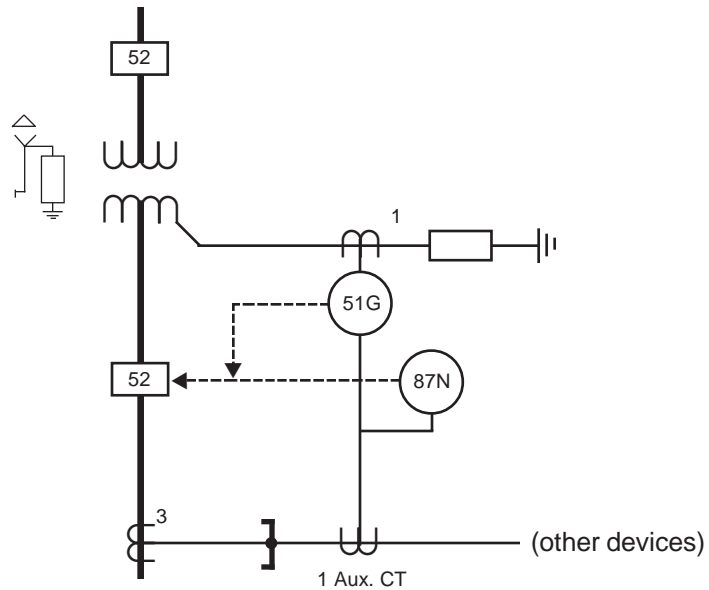

Device list for Additional Transformer Ground Protection

- 51G Time overcurrent
- 87N Ground differential

Qty.	Device No.	Description	GE Model No.
<u>Alternate Package (Single Phase Units)</u>			
1	51G	Time Overcurrent Relay	DIFC or IFC53A
1	87N	Ground Differential Relay	IFD51D

**Note: The SR745 digital transformer relay includes 87N.*

BUS BUS

Protective Zone (BUS1)

Single source, radial configuration:

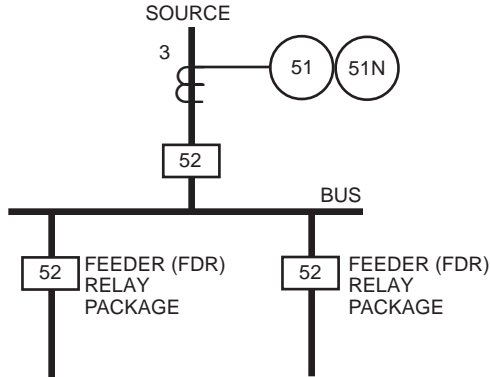

Device list for BUS1

51 Phase overcurrent
51N Ground fault

Qty.	Device No.	Description	GE Model No.
		Basic Package	
1	51/51N	Phase Overcurrent and Ground Fault Relay	MDP or SR735
		Alternate Package (Single Phase Units)	
3	51	Phase Overcurrent Relay	DIFC or IFC53A
1	51N	Ground Fault Relay	DIFC or IFC53A
		Second Alternate Package	
1		Multifunction microprocessor-based relay system including the following functions:	DFP100 or DFP200 or SR750
	27	Undervoltage	
	46	Negative Sequence Overcurrent (DFP100 & 200 only)	
	47	Negative Sequence Voltage (SR750 only)	
	51	Phase Overcurrent	
	51N	Residual Overcurrent	
	59	Overvoltage	
	74LM	High Impedance Ground (DFP200 only)	
	81L/H	Frequency	
		Options	
1	64	Ground Fault Relay (ungrounded systems)	TCCV

BUS BUS

Protective Zone (BUS2)

Multiple sources with bus tie breaker:

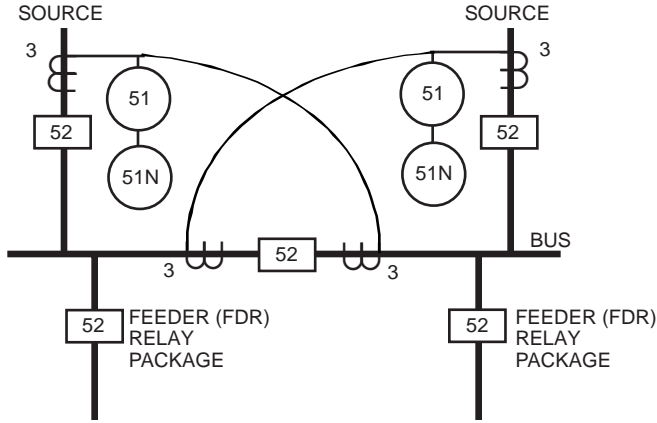

Device list for BUS2

51 Phase overcurrent
51N Ground fault

Qty.	Device No.	Description	GE Model No.
		Basic Package	
1	51/51N	Phase Overcurrent and Ground Fault Relay	MDP or SR735
		Alternate Package (Single Phase Units)	
3	51	Phase Overcurrent Relay	DIFC or IFC53A
1	51N	Ground Fault Relay	DIFC or IFC53A
		Second Alternate Package	
1		Multifunction microprocessor-based relay system including the following functions:	DFP100 or DFP200 or SR750
	27	Undervoltage	
	46	Negative Sequence Overcurrent (DFP100 & 200 only)	
	47	Negative Sequence Voltage (SR750 only)	
	51	Phase Overcurrent	
	51N	Residual Overcurrent	
	59	Overvoltage	
	74LM	High Impedance Ground (DFP200 only)	
	81L/H	Frequency	
		Options	
1	64	Ground Fault Relay (ungrounded systems)	TCCV

BUS BUS

Protective Zone (BUS3)

Single or multiple sources, with or without bus tie breakers:

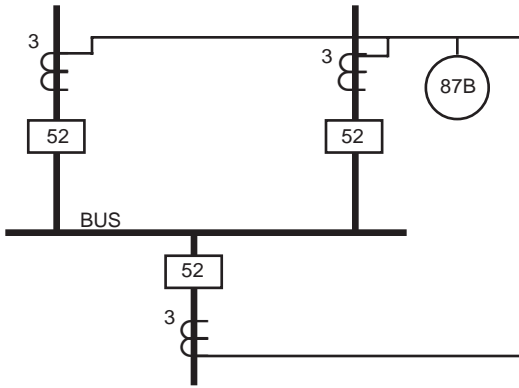

Device list for BUS3

87B Differential

Qty.	Device No.	Description	GE Model No.
3	87B	Basic Package Differential Relay	PVD21 or SBD11

BUS BUS

Protective Zone (BUS4)

Multiple sources, bus tie breakers, multi-ratio CT's:

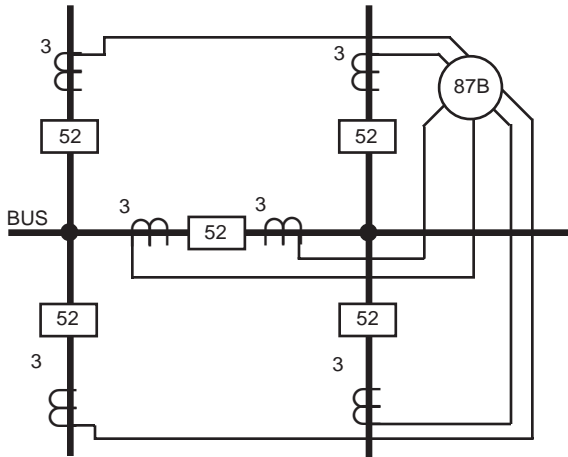

Device list for BUS4

87B Differential

Qty.	Device No.	Description	GE Model No.
1	87B	Basic Package Differential Relay	BUS1000

IL INCOMING LINE

Protective Zone (IL1)

Single source incoming line (no internal generation):

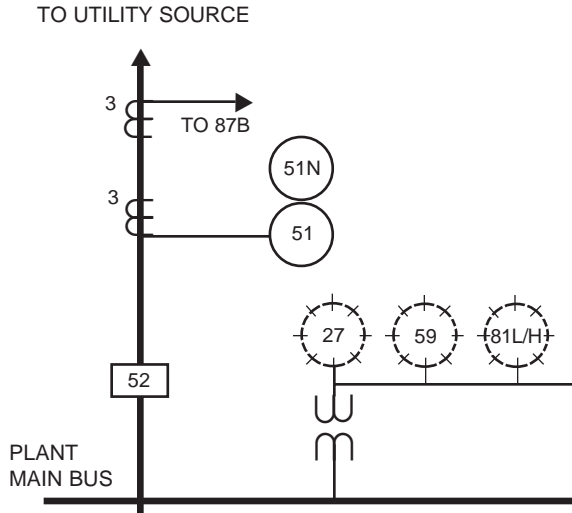

Device list for IL1

27	Undervoltage
51	Phase overcurrent
51N	Residual overcurrent
59	Overvoltage
81L/H	Frequency

Qty.	Device No.	Description	GE Model No.
Basic Package			
1	51/51N	Phase Overcurrent and Ground Fault Relay	MDP
First Alternate Package			
1	51/51N 74LM	Phase and Ground Overcurrent Relay with High Impedance Ground Fault Detection (Power Quality Option)	DFM3
Second Alternate Package			
1		Multifunction microprocessor-based relay system including the following functions:	DFP100 or DFP200 or SR750
	27	Undervoltage	
	46	Negative Sequence Overcurrent (DFP100 & 200 only)	
	47	Negative Sequence Voltage (SR750 only)	
	51	Phase Overcurrent	
	51N	Residual Overcurrent	
	59	Overvoltage	
	74LM	High Impedance Ground (DFP200 only)	
	81L/H	Frequency	
Options (Single Phase Units)			
4	51, 51N	Phase/Ground Overcurrent Relays	DIFC or IFC53A
1	27	Undervoltage Relay	TOV or NGV
1	59	Overvoltage Relay	TOV or NGV
1	81L/H	Over and underfrequency Relay (add if upstream auto-reclosing is a concern)	SFF202B or MFF1
1	87B	Differential Relay (See Bus Protective Zone for Details)	

IL INCOMING LINE

Protective Zone (IL2)

Single source incoming line via utility transformer (no internal generation):

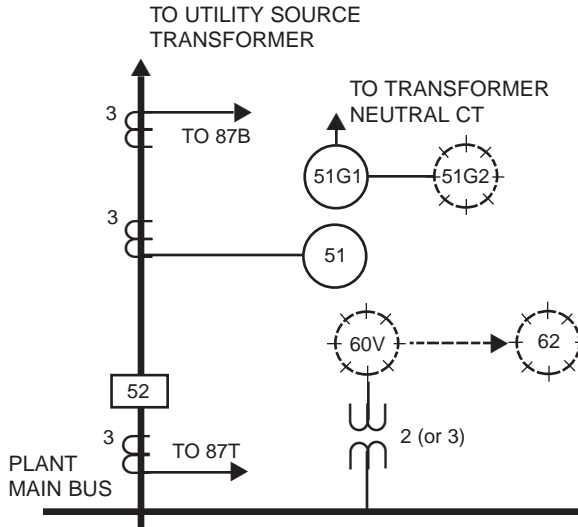

Device list for IL2

51	Phase overcurrent
51G-1	Ground overcurrent
51G-2	Ground overcurrent
60V	Voltage unbalance
62	Timer

Qty.	Device No.	Description	GE Model No.
Basic Package			
1	51/51G	Phase Overcurrent and Ground Fault (Bus) Relay	MDP
First Alternate Package			
1	51/51G/ 74LM	Phase and Ground Overcurrent Relay with High Impedance Ground Fault Detection (Power Quality Option)	DFM3
Second Alternate Package			
1		Multifunction microprocessor-based relay system including the following functions:	DFP100 or DFP200 or SR750
	27	Undervoltage	
	46	Negative Sequence Overcurrent (DFP 100 & 200 only)	
	47	Negative Sequence Voltage (SR750 only)	
	51	Phase Overcurrent	
	51N	Residual Overcurrent	
	59	Overvoltage	
	74LM	High Impedance Ground (DFP200 only)	
	81L/H	Frequency	
Options (Single Phase Units)			
4	51, 51N	Phase/Ground Overcurrent Relays	DIFC or IFC53A
1	60V	Voltage Unbalance Relay (add if high side fusing could result in single phase of motors)	NBV11
1	62	Timing Auxiliary Relay	SAM201 or IAV51M
1	51G2	Ground Fault (transformer secondary) Relay (add for two step trouble-shooting for transformer/bus grounds)	DIFC or IFC53A
1	87B and 87T	Differential Relay (See Bus and Transformer Protective Zones for Details) (For additional options see IL1)	

IL INCOMING LINE

Protective Zone (IL3)

Single source incoming line with internal generation:

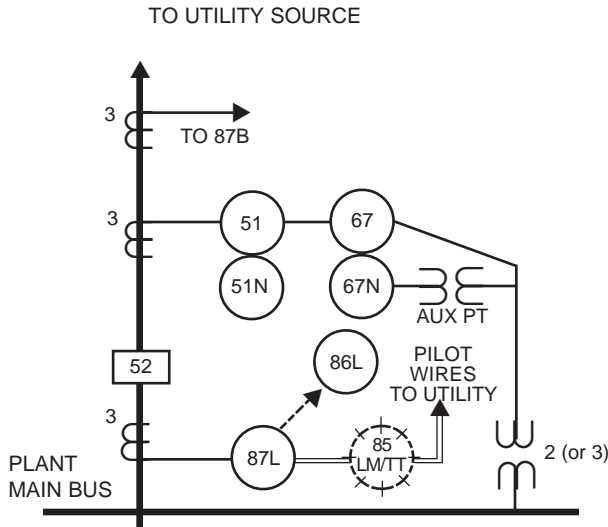

Device list for IL3

51	Phase overcurrent
51N	Residual overcurrent
67	Directional phase overcurrent
67N	Directional ground overcurrent
85LM/TT	Communication monitor
86L	Lockout auxiliary
87L	Differential

Qty.	Device No.	Description	GE Model No.
Basic Package			
1	87L	Pilot Wire Line Differential Relay	SPD11*
1	86L	Lockout Auxiliary Relay	HEA61
1	67/67N	Directional Phase and Ground Overcurrent Relay	MOR3
1	51/51N	Phase Overcurrent and Ground Fault Relay	MDP
Alternates			
1	87L/85LM/ 85TT	Line Differential & Channel Monitor & Transfer Trip Auxiliary Relay	DLS3*
3	67	Directional Phase Overcurrent Relay (Single Phase Units)	IBC53 or JBC53
1	67N	Directional Ground Overcurrent Relay (Single Phase Units)	IBCG53 or JBCG53
4	51, 51N	Phase/Ground Overcurrent Relays (Single Phase Units)	DIFC or IFC53A
Options			
1	85LM	Pilot Wire Monitor [different device at send and receive ends] Relay	SPA11A or 12A*
1	85LM/TT	Pilot Wire Monitor and Transfer Trip Auxiliary Relay [different device at send and receive ends]	SPA11B or 12B*
1	87B	Differential Relay (See Bus Protective Zones for Details) (For additional alternates and options see IL1 and IL2)	

Notes:

*Must be selected in accordance with companion relay at opposite end of the line. Pilot wire protective auxiliaries may be required.

IL INCOMING LINE

Protective Zone (IL4)

Dual source incoming line (dual line with internal generation & via utility transformer):

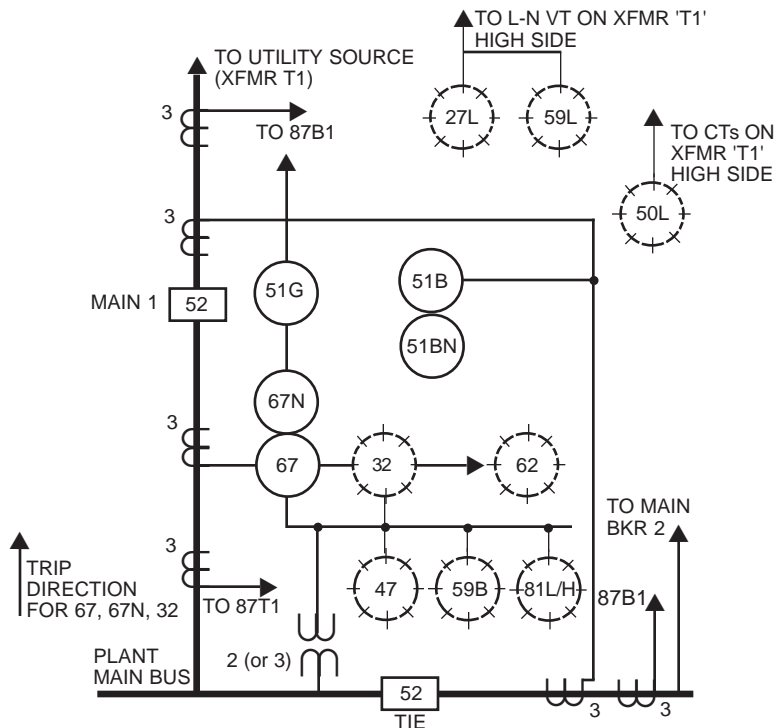

Device list for IL4

- 27L Undervoltage
- 32 Power direction
- 47 Phase undervoltage and reverse phase sequence
- 50L Instantaneous overcurrent
- 51B Phase time overcurrent
- 51BN Residual time overcurrent
- 51G Ground overcurrent
- 59B Overvoltage
- 59L Overvoltage
- 62 Timer
- 67 Directional phase overcurrent
- 67N Directional ground overcurrent
- 81L/H Frequency

Qty.	Device No.	Description	GE Model No.
Basic Package			
1	67/67N	Directional Phase and Ground Overcurrent Relay	MOR3
1	51B/51BN	Phase Overcurrent (Partial Differential) and Ground Fault Relay	MDP
1	51G	Ground Overcurrent (for transformer lowside) Relay	DIFC
Options			
1	27L	Line Undervoltage (transformer highside) Relay	TOV5 or NGV
1	59L	Line Overvoltage (transformer highside) Relay (Add 27L & 59L as a means of detecting Delta-Wye transformer highside ground fault after utility separation.)	TOV5 or NGV
1	32	Power Directional Relay (detects transf. magnetizing current)	CCP13E
1	62	Auxiliary Timing Relay (add 32 & 62 in lieu of 27L and 59L as alternate means of detecting system ground faults)	SAM201
1	47	Phase Undervoltage and Reverse Phase Sequence Relay (add if required for motor bus monitoring or intertie)	ICR53A
1	59B	Bus Overvoltage Relay (add if required for intertie)	TOV5 or NGV
1	81L/H	Over and Underfrequency Relay (add for intertie or load shedding requirements)	SFF202B or MFF1
1	50L	Instantaneous Overcurrent Relay (add if highside disconnect is not rated for fault interruption)	PJC11AV or CHC11A
1	87B and 87T	Differential Relay (See Bus and Transformer Protective Zones for Details) (For additional alternates and options see IL1 and IL2)	

RELAY INDEX

MODEL	DESCRIPTION	DEVICE NO.
239	Small HP MV motor management relay	49/50/51(+)
269 PLUS	Medium HP MV motor management relay	87(+)
469	Large HP MV motor management relay with metering	87(+)
489	Small/medium size generator relay	87(+)
735/737	3 phase + ground feeder relay	50/51
745	Transformer management relay	87(+)
750/760	Multifunction feeder relay	50/51(+)
ALPS	High speed distance relay	21(+)
BDD	Transformer differential, harmonic restraint	87
BUS1000	Bus protection relay	87
CAP	Power directional	32
CCP	Power directional	32
CEB	Phase offset MHO distance	21, 68
CEH	Loss of excitation	40
CEX57	Angle impedance	78
CEY	Phase MHO distance	21
CEY-IAC	Phase distance overcurrent	21/50/51
CEYG	Ground MHO distance	21N
CFD	Machine differential	87
CFV	Instantaneous overvoltage	59
CFVB	Voltage balance	60
CHC	Instantaneous overcurrent	50
CJCG	Ground directional overcurrent	67
CLPG	Carrier ground	67
DAR	Reclosing	79
DBF	Breaker failure relay	50BF
DBT	Breaker coil/tripping circuit supervision relay	74
DDS	Digital distribution system	50/51(+)
DFF	Frequency relay	81
DFM	Feeder monitor + hi impedance ground	51/51G/74
DFP100	Multifunction feeder relay with reclose	50/51(+)
DFP200	Multifunction feeder + hi impedance ground	50/51/74(+)
DGP	Generator protection	87(+)
DIAC	Time overcurrent relay	51, 50/51
DIFC	Time overcurrent relay	51, 50/51
DLP	Distance relay	21(+)
DLS	Current differential line protection	87(+)
DSFC	Time overcurrent relay	51, 50/51
DTP	Transformer protection relay	87
GCX	Phase reactance distance	21
GCY	Phase MHO distance	21
GGP	Sensitive power directional	32
GSY	Generator out-of-step	78
GXS	Auto sync/sync check	25
HAA	Annunciator auxiliary	30, 74
HEA	Auxiliary lockout	86
HFA	Multicontact auxiliary	86, 94
HFC	Instantaneous overcurrent	50
HGA	Contact auxiliary	27, 74, 94
HGA18	Reclosing	79
HMA	Contact auxiliary	27, 74, 94
HSA	Auxiliary lockout	86
IAC	Time overcurrent	51, 50/51
IAV	Time over/under voltage	27, 59, 64
IBC	Phase directional overcurrent	67
IBCG	Ground directional overcurrent	67N
ICR	Undervoltage and phase sequence	47
ICW	Time over/underpower	32, 37
IFC	Time overcurrent	51, 50/51
IFCS	Time overcurrent with voltage control	51
IFCV	Time overcurrent with voltage restraint	51V

MODEL	DESCRIPTION	DEVICE NO.
IFD	Transformer differential	87
IFV	Time overvoltage	59, 64
IJC	Current balance	46
IJD	Machine differential	87
IJF	Over/under frequency	81
IJS	Synchronism check	25
IRT	Temperature	38, 49
JBC	Phase directional overcurrent	67
JBCG	Ground directional overcurrent	67N
JBCV	Directional overcurrent, voltage restraint	67
LPS	Distance relay	21(+)
MCP	Capacitor bank protection	50/51(+)
MDP	3 phase + ground feeder relay	50/51
MFF	Over/under frequency	81
MGC	Small generator protection	46, 49, 51
MIC	Overcurrent	50/51
MLJ	Synchrocheck	25
MLP	Three pole tripping distance relay	21
MMC	Small motor protection	49/50(+)
MOR	Directional overcurrent with reclosing	50/51/79
MRC	Thermal image	49, 50/51
MRS	Transmission line reclosing	79
NAA	Pilot/distance auxiliary	78, 85
NBT	Breaker trip supervisor	74
NBV	Voltage balance	47, 60
NGA	Contact auxiliary	94
NGV	Instantaneous under/over voltage	27, 59
NLR	Multi-shot reclosing	79
NSR	Single-shot reclosing	79
OST	Out-of-step protection	78
PJC	Instantaneous overcurrent	37, 50, 76
PJG	Machine field ground	64
PJV	Over/under voltage	27, 59
PLS	Polyphase transmission line protection system	21(+)
PVD	Bus differential	67
SAM	Time delay	2
SBA	Breaker auxiliary	94
SBC	Breaker backup	50BF
SBD	Bus differential	87
SCA	Directional comparison, blocking auxiliary	85
SFF	Over/underfrequency	81
SGC	Negative sequence overcurrent	46
SLJ	Synchronism check	25
SLR	Multi-shot reclosing	79
SLV	Over/under voltage	27, 59
SLY	Phase distance	21, 68
SLYG	Ground distance	21N, 68
SPA	Pilot wire monitor	85
SPD	AC pilot wire	87
SPM	Synchronous motor controller	50/55/27(+)
STD	Transformer differential	87
STV	Overexcitation (V/Hz)	24
TCC	Directional overcurrent	67
TCCV	Ground fault	64
TCW	Directional power	32
TLS	Phase/zone transmission line protection system	21(+)
TOC	Overcurrent	50/51
TOV	Over/under voltage	27, 59
TRS	Transmission line reclosing	79
TTS	Transformer differential	87
TYS	Phase/zone transmission line protection system	21(+)

ANSI DEVICE NUMBERS/DESCRIPTION

2 Time-delay	37 Undercurrent or underpower	50 Instantaneous overcurrent	67 AC directional overcurrent	79 AC reclosing
21 Distance	38 Bearing	51 AC time overcurrent	68 Blocking	81 Frequency
25 Synchronism-check	40 Field	59 Overvoltage	69 Permissive	85 Carrier or pilot-wire
27 Undervoltage	46 Reverse-phase	60 Voltage balance	74 Alarm	86 Lock out
30 Annunciator	47 Phase-sequence voltage	63 Pressure	76 DC overcurrent	87 Differential
32 Directional power	49 Thermal	64 Apparatus ground	78 Out-of-step	94 Tripping

REFERENCES

U.S. Standards

ANSI	ANSI/IEEE	Title
1.	100-1992	Standard Dictionary of Electrical and Electronic Terms
2.	375-1975 (R1989)	Graphic Symbols for Electrical and Electronic Diagrams
3. Y14.15-1996 (R1988)		Electrical and Electronics Diagrams
4.	C37.2-1991	Electrical Power System Device Function
5.	C37.90-1989	Relays and Relay Systems Associated with Electric Power Apparatus
6.	C37.95-1989	Guide for Protective Relaying of Utility-Consumer Interconnections
7.	242-1986 (R1991)	Recommended Practice for Protection and Coordination of Industrial and Commercial Power Systems

European Standards

8. IEC-255 Protective Relay Standards

Codes

9. 1993 National Electrical Code • NFPA Publication 1993

Books

10. Industrial Power Systems Handbook • D.L. Beeman, Editor, McGraw-Hill Book Co., 1955

Standards may be purchased from:

American National Standards Institute, Inc.
11 West 42nd Street
New York, NY 10036

Institute of Electrical and Electronics Engineers, Inc.
Service Center
445 Hoes Lane
Piscataway, NJ 08855

National Fire Protection Association
1 Batterymarch Park
Quincy, MA 02269

Note: IEC Standards may be purchased from the American National Standards Institute.

Relay Selection Guide



MULTILIN

GE Power Management

UTILITY

GE Power Management

205 Great Valley Parkway
Malvern, PA
USA 19355
Tel: (610) 251-7000

INDUSTRIAL

GE Multilin

215 Anderson Avenue
Markham, Ontario
Canada L6E 1B3
Tel: (905) 294-6222

EUROPE

GEPCE

Avenida Pinoa 10
48016 Zamudio Vizcaya
Spain
Tel: +34-4-485-8800

<http://www.ge.com/edc/pm>

GET-8048A

TCC/MPI - 01.98 - 1000