



F650 Feeder/Bay Protection System

Revision 3.40 release notes

GE publication number: GER-4088

Copyright © 2006 GE Multilin

Overview

Summary

This document contains the release notes for the 3.40 release of the F650 Feeder/Bay Protection System.

- Affected products: F650 Feeder/Bay Protection System
- Date of release: July 25, 2006
- Firmware revision: 3.40
- Bootcode revision: 4.10

Description

The version 3.40 release is compatible with Enervista 650 Setup version 3.40 and F650 relay operation with hardware 01 or higher (refer to *Upgrade paths* on page 3 for details).

Release details

In the following change descriptions, a revision category letter is placed to the left of the description. Refer to the Appendix at the end of this document for additional details.

New features

N **Communications: Procome communication protocol implemented.**

Procome is a communication protocol focused on control operations. Commands to read data as status, measurements, events and counters have been implemented together with commands to perform operations and synchronization.

N Wattmetric ground fault protection: new function implemented for 3.40 release

A sensitive wattmetric zero-sequence directional function can be used on isolated or resonant (Petersen coil) grounded, low-resistance grounded and solidly grounded systems to detect ground faults. The function determines the presence and direction of ground faults by measuring the value and direction of zero-sequence power.

The element responds to power derived from zero-sequence voltage and current in a direction specified by the element characteristic angle. The angle can be set within all four quadrants, and the power can be selected as active, reactive, or apparent. Therefore, the element may be used to sense either forward or reverse ground faults in inductive, capacitive, or resistive networks. An inverse time characteristic allows time coordination of the elements across the network.

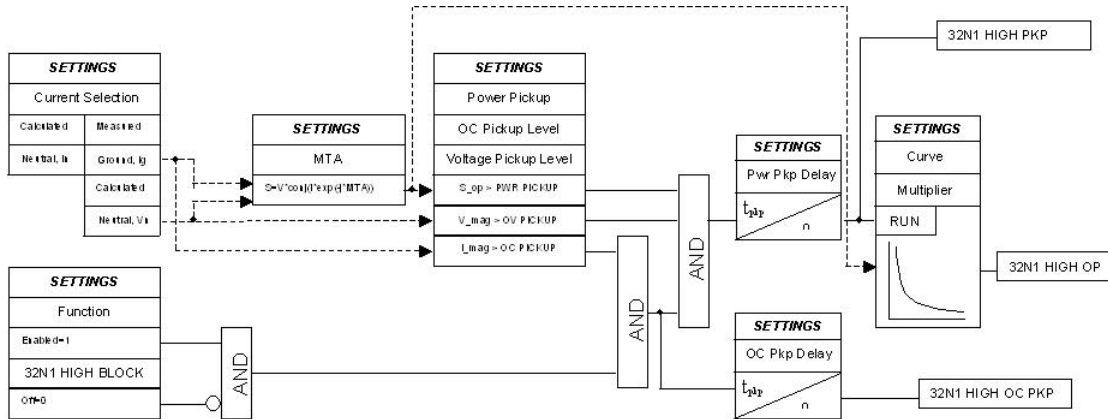

The time delay characteristic can be definite time, inverse time, or any timing curve programmed with user curves. There are two elements available in the relay.

Modified features

C Communications: select-before-operate (SBO) functionality added to IEC 61850 protocol features

The IEC 61850 capability is further enhanced in F650 by adding SBO function. Besides existing "Direct with normal security" option, three more options have been added: "Direct with enhanced security", "SBO with normal security" and "SBO with enhanced security".

Upgrade paths

It is our recommendation that all customers upgrade to the latest version of F650 firmware to take advantage of the latest developments and feature enhancements. Firmware upgrades can be easily performed using the Energvista 650 Setup software. This software can also convert settings files from an older version to the latest version.

Upgrade path for hardware 01 and above

For F650 relays with hardware 01 and above, the revision 3.40 release can be uploaded to the F650 CPU via the Energvista F650 Setup software. Upgrade package must be obtained from GE Multilin to upgrade the relays from hardware 01 to hardware 02.

Upgrade path for hardware 00

For F650 relays with hardware 00, an upgrade package must be obtained from GE Multilin to upgrade the relays CPU to hardware 0X

Benefits of hardware 01 and above.

The benefits of hardware 01 and above are as follows:

- IEC 61850 communications protocol.
- 32 digital inputs and analog inputs options for I/O boards.
- IEC symbols in graphical display (only with hardware 02).

Appendix

Change categories

This document uses the following categories to classify the changes.

Table 1: Revision categories

Code	Category	Comments
N	New feature	A separate feature added to the relay. Changes to existing features even if they significantly expand the functionality are not in this category
G	Change	A neutral change that does not bring any new value and is not correcting any known problem
E	Enhancement	Modification of an existing feature bringing extra value to the application
D	Changed, incomplete or false faceplate indications	Changes to, or problems with text messages, LEDs and user pushbuttons
R	Changed, incomplete or false relay records	Changes to, or problems with relay records (oscillography, demand, fault reports, etc.)
C	Protocols and communications	Changes to, or problems with protocols or communication features
M	Metering	Metering out of specification or other metering problems
P	Protection out of specification	Protection operates correctly but does not meet published specifications (example: delayed trip)
U	Unavailability of protection	Protection not available in a self-demonstrating way so that corrective actions could be taken immediately
H	Hidden failure to trip	Protection may not operate when it should
F	False trip	Protection may operate when it should not
B	Unexpected restart	Relay restarts unexpectedly

The revision category letter is placed to the left of the change description.

GE Multilin technical support

GE Multilin contact information and call center for product support is shown below:

GE Multilin
215 Anderson Avenue
Markham, Ontario
Canada L6E 1B3

Telephone: 905-294-6222 or 1-800-547-8629 (North America), +34 94 485 88 00 (Europe)

Fax: 905-201-2098 (North America), +34 94 485 88 45 (Europe)

E-mail: multilin.tech@ge.com

Home Page: <http://www.GEmultilin.com>