



# Heavy-Duty Power In a Light Package

Spectra™ Series Busway makes the most sense for commercial and industrial electrical distribution applications that require up to 5,000 amps of capacity with short-circuit protection.

Since Spectra™ Series Busway is lighter than wire and conduit, it's easier to handle and hang. Its compact design is ideal for applications where space is critical and eliminates the time-consuming tasks of stripping, preparing and pulling wire. All of these advantages translate into lower delivery costs, simple storage and handling, lower total installed costs, and increased space for more equipment.

Spectra™ Series Busway provides you with maximum flexibility. In contrast to the fixed nature of wire and conduit, busway will grow as your facility expands. Due to its modular design, busway runs can be easily added, or disassembled and relocated with minimal effort.

The greatest testimonial to GE busway is actual field experience. GE is a market leader and preferred product for a wide variety of demanding applications. Many of our busway products are still being used in these environments after more than 30 years.

From every point of view – flexibility, performance and initial cost -- Spectra™ Series Busway is the clear choice for your next installation.

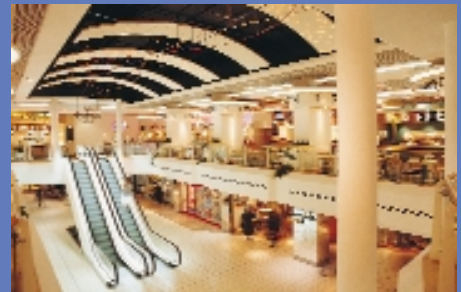

# Spectra™ Series Busway

Customer feedback and structured focus groups provided the foundation for this busway product. Customers asked for lighter and smaller power bus systems that were flexible enough to expand or realign in facilities as needs changed. They needed higher amperage tap-offs and the ability to isolate sections without taking the entire structure offline. They asked for joints that were sturdy, safe and easy to maintain, but were flexible enough to accommodate late-point installation issues.

## Simpler Is Better

GE produced a compact design resulted in these improvements over wire and conduit installations:

- **50% minimum decrease in size**
- **Up to 50% decrease in weight**
- **Increased adaptability and versatility**
- **Higher short circuit ratings**
- **Improved installation and operational safety**
- **Fully tested and certified to UL, ANSI, CSA and ASTA standards**

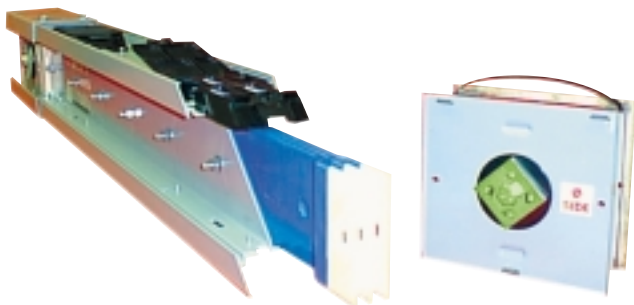

## Key Features & Benefits

### Decreased Size

In a typical 1200 amp ceiling-hung application, busway will run 4.5"x7" vs. 4"x16" with wire and conduit. This allows busway to run in more places around and in between existing pipe and ductwork.

### Decreased Weight

In the same 1200 amp, 3 wire application, aluminum busway weighs only 8 lbs./foot vs. 19 lbs./foot with copper wire and EMT conduit. This dramatically saves on your structural weight allowance making more efficient distribution designs possible and reduces installation time (per NECA labor standards).

### Frequent High Amperage Tap-Offs

A bolted power take off device provides up to 1600 amps protection at every joint, plug-in or feeder. Additionally, tap-off provisions on standard busway allow for 10 locations per 10 foot section. These features offer maximum flexibility in designing or modifying your distribution system.

### Section Isolation Without Long Shutdowns

Removeable isolation joints allow an operator to cleanly and safely remove a section of busway and allow the remaining system to come back on-line. This allows ease of maintenance and modification with minimal facility downtime.

### Zone 4 Seismic Certification Standard

Spectra™ Series Busway can be used in applications ranging up to Zone 4 Seismic conditions without restrictions, special bracing, connections to equipment, or hangers. This saves on installation time and costs due to additional components.

### Virtually No Maintenance

When fully torqued, GE Belleville joint washers have a high deflection, losing only 14% of their contact force over an expected 50 year life. This prevents overheating joints – the primary cause of busway maintenance.

## Smaller Size

Spectra™ Series Busway dimensions begin at 4.5"x4.4" for 225-800 ampere ratings, and range up to only 4.5"x23" for the highest ratings. A single drop-rod hanger per 10-foot section can be used for ratings up to 2000 amp for aluminum busway and 2500 amp for copper busway.

## Flexibility

Spectra™ Series Plug-In Busway has tap-off provisions at 24" intervals on both sides, leaving a total of ten locations per 10-foot section. This allows safe and quick connection of a switch (up to 600 amp) or circuit breaker (up to 800 amp). Load-side cable connections from the busway circuit breaker, fuse or plug to your equipment are short and direct.

A Spectra™ Series Busway plug can be installed or removed safely within a matter of minutes. The plug-assist and position plug locators simplify operation, ensuring a safe and positive connection.

In addition, a  $\pm 1/2$ " adjustability built into every Spectra™ Series Busway joint allows you greater freedom during installation and adjustment.

## Safe Operation

Spectra™ Series Busway has many features that ensure safe operation by your personnel:

- Conductors that are totally enclosed**  
 Ensures that the highest standards for safety are maintained per UL guidelines.
- Polarized plug-in units**  
 Polarized engagement of the plug to the busway provides the installer with positive plug/phase alignment.
- Plug-in units on installation are automatically grounded**  
 First-Make-Last-Break type contactors help protect the user during installation and removal of bus plugs.
- Cover, device and plug interlocks**  
 Helps to protect the installer by prohibiting the opening of the plug door or removal when the plug is in the ON position.
- Provision for padlocking the plug in the OFF position**  
 With up to 3 lock positions per plug, this product fully supports your Lock-Out/Tag-Out (LOTO) program to prevent unauthorized user access to your electrical distribution system.
- Integral Housing Ground**  
 GE's all-aluminum housing forms a complete 360° high level ground path for ground faults and serves as a continuous bond between busway sections, fittings and bus plugs.

Common Application - 2000 Amp,  
600 Volt, 3 Phase / 4 Wire

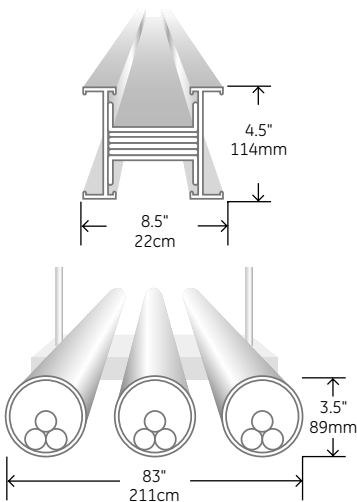

Requires 12, 500 MCM Cables  
in 6" Rigid Conduit

### Compact Size

Amperes	AL	CU
225-600	4.375	4.375
800	5.625	4.375
1000	6.125	5
1200	7	5.625
1350	8.5	6.125
1600	9.25	7
2000	11	8.5
2500	15.5	10.25
3000	18	15
4000	23	18
5000	-	21.5

### Dimensions

Representative in inches for aluminum and copper housings. All depths are 4.5".

### Low Weight

Amperes	AL3W	4W	CU3W	4W
225-600	4	5	6	7
800	6	7	8	9
1000	7	8	10	12
1200	8	9	12	15
1350	9	10	14	17
1600	10	12	16	20
2000	12	15	21	26
2500	17	20	29	37
3000	19	23	32	40
4000	25	30	42	52
5000	-	-	58	74

### Pounds / 1 Foot Run

Representative for aluminum and copper housings with 3 wire and 4 wire applications.

## Longevity & Durability

Insulation is at the heart of any electrical distribution system, and a durable, long-life epoxy insulation is used in Spectra™ Series Busway.

Spectra™ Series Busway 130° C Class B epoxy insulation is unique in the world of low-voltage busway. Epoxy insulation has been in use with GE armor-clad feeder busway for the past 30 years. When compared to PVC and Mylar, test results show that epoxy has a significantly longer life (50 years), higher impact strength (150 lbs) and superior chemical and water resistance. Epoxy is impervious to acids, alkalis, acetones, machining oils and lubricants commonly found in industrial environments.

Epoxy-coated busway tested for flammability were rated self-extinguishing by UL laboratories. This is in contrast to PVC, which emits poisonous fumes in a fire.

The Belleville spring joint design has been tested in over 35 years of field experience. Once properly tightened, it does not have to be retightened each year, as some manufacturers recommend. It only requires a periodic visual inspection.

## Seismic Certification

The complete standard commercial offering of Spectra™ Series Busway is certified for Zone 4 Seismic conditions as witnessed and approved (by the tests performed) at Wyle Laboratories in Huntsville, Alabama. The maximum acceptable parameters are below.

## Fully Tested

Spectra™ Series Busway has undergone thorough testing according to ANSI/UL 857, NEMA BU-1, federal specification W-B-811b, CSA and ASTA. Testing included (but was not limited to) heat rise, short circuit and ground fault.

### Installation Labor Costs

Labor Hrs / ft.

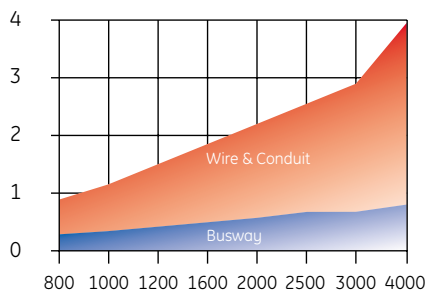

### Aluminum Housing

Spectra Series Busway plug-in labor measurements are the same as feeder labor measurements

Labor Hrs / ft.

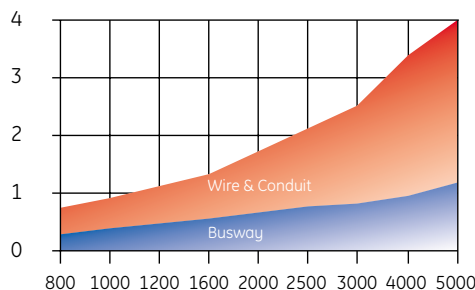

### Copper Housing

### Seismic 5 Certification

Parameters according to vertical riser and horizontal configurations

Maximum Acceptable Parameters	Vertical	Horizontal
Edgewise & Flatwise Orientation	✓	✓
Ratings	2500A CU 4000A AL	5000A CU 4000A AL
Voltage	600V	600V
Distribution Plug-In & Feeder Standard Hangers	✓	✓
Hanger Spacing	16 Feet	10 Feet
Full Threaded Drop Rod	✓	✓
Drop Rod Connection	N/A	*
Bus Plugs	✓	✓
Fittings	✓	✓
Cable Tap Boxes	✓	✓
End Boxes	✓	✓
All Applications Approved	✓	✓
Proximity to Walls	*	*

\* Drop rod must be bolted through ceiling/floor and secured on both sides with standard washers and nuts.

## Adaptability & Versatility

A wide variety of Spectra™ Series Busway options are available to fit your specific application. Most of your applications will fall into four categories.

- **Service Entrance**  
Brings power from utility transformers into a main disconnect or distribution switchboard
- **Single Load**  
A long horizontal busway run that feeds a single load, such as a switchboard or motor control center
- **Multiple Load**  
Used where power requirements are distributed over a large area, such as with production machinery
- **Riser**  
Vertical run to economically feed high-rise buildings

Spectra™ Series Busway is available in both silver-plated aluminum and tin-plated copper at amperage capacities of 225-5000 AC and 600-8000 DC for low voltage applications. Variations and components are available for all indoor, drip-proof and outdoor applications. GE also offers a wide variety of tap-off devices, of which fusible switches and molded case circuit breakers are the most common. Busway plugs available in E, F, G and K frames provide you with the following benefits:

- Simplified field changeover with adjustable trip-amp rating plug
- More accurate and reliable trip interruption with true digital sensing
- Higher interruption capacity
- Optimal service life, performance and safety

### Weather Joint Protection

Construction Type	IEC Degree Required	Joint Insulator
Indoor Feeder, Plug-in, Riser	IP-40	Standard
Drip Proof Feeder, Plug-in, Riser	IP-43	Standard
Splash Proof Feeder, Plug-in, Riser	IP54	Weathershield
Outdoor Feeder (NEMA 3R)	IP65/66	Weathershield

## Weather Protection

Spectra™ Series Busway provides optimum performance in even the most severe weather environments.

- WeatherShield™ Epoxy Joint Insulators are designed for long life and help to reduce maintenance. Joint bolt access is via easily removeable, UL listed/CSA certified rain-tight santoprene plugs.
- In addition to our standard housing draw holes, extra drainage channels through die cast housing spacers help eliminate standing water near joints.
- Gasketing materials and sealants are rated for extreme temperatures (-40° to 250° F and -40° to 200° F respectively) and are tested to verify superior UV resistance and excellent stability when subjected to long term thermal aging.

The joint shield, as shown in the photo below, uses an integral spring latch clamping system. This system provides optimum gasket compression at all joint connections, and eliminates the need for additional joint cover hardware.

### Splash-Proof Applications

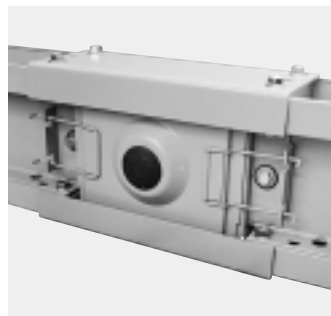

Innovative Joint Shield design provided with drip-proof, splash-proof and outdoor bus.

### Outdoor Applications



Complete outdoor run of Spectra Series Busway.

## Double-Headed "Break Off" Joint Bolt

This bolt is the standard joint bolt offering for all Spectra™ Series Busway.

- When the bolt is properly tightened, the outer head will break off removing the bright red label sandwiched underneath. This will help eliminate any errors of omission during installation by giving a quick visual inspection.
- No torque wrench is required for initial installation.
- The bolt is reusable after the top head is broken off by using a standard torque wrench on the second bolt head.



## Joint Guard™ Torque-Color Indicator Bolt

GE's exclusive Joint Guard™ Bolt acts as a protection system which shows you, with color, whether a busway joint is loose or tight.

The center spot is bright red when a joint is loose and turns dark when proper torque is applied. It does this, not just once, but even after repeated tightening and loosening so often required during installation. And it will keep on working that way for years to come.

Joint Guard™ simplifies periodic maintenance with visual inspection – even from a distance. This bolt eliminates labor-intensive re-torquing and gets even easier when combined with the superior torque-retention design of the Belleville washer. Both elements deliver the best solution for your maintenance program.



### How it Works

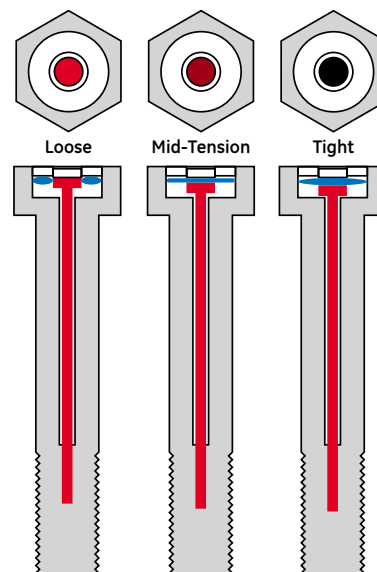

Joint-Guard technology was developed for the nuclear and aerospace industries. It measures the elongation of the busway joint bolt, and is more accurate than a torque wrench, which is subject to substantial variations in static and dynamic friction, depending on thread wear and lubrication.

USA  
41 Woodford Avenue  
Plainville, CT 06062

GE Consumer & Industrial  
Electrical Distribution

[www.geelectrical.com](http://www.geelectrical.com)

© 2005 General Electric Company  
All Rights Reserved



imagination at work