

# GE Arc Vault™ Protection System

By Mark Clapper  
GE Specification Engineer

## Introduction

To address the increasing concerns and standards around arcing faults, GE challenged our Global Research Center to develop a new, “active” method of detecting & removing an arcing fault. The goal was to develop a technology that would, in simple terms, reduce the potential for injury and equipment damage. The result is an innovative product called the Arc Vault™ Protection System. This article will outline some basic arc flash mitigation techniques, and culminate with a description of the new GE technology. It should be noted from the onset that this technology is currently in the prototype phase and that the discussion covers applications of 600V and below.

Let’s start with the basic question of why is the industry concerned with arcing faults? If the reader is unfamiliar with arcing faults, please refer to the newsletter article titled “Arc Flash Basics” before continuing.

## Arcing faults – Why the Industry Concern?

Simply put, the affects may result in serious injury, death, equipment damage, and downtime. Unlike the bolted fault, an arcing fault uses ionized air as the conductor. The cause of the fault normally burns away during the initial flash and the arc is sustained by the establishment of a highly conductive, intensely hot plasma arc. The intense heat vaporizes conductors/ barriers and superheats the surrounding air resulting in an explosive volume-metric increase within the space. The consequence is an intense pressure wave, deafening sound, blinding light, toxic gases, molten metal and shrapnel. This is often referred to as the arc blast. Unless action is taken to either quickly remove the fault or redirect the arc blast, the brunt of these items will impact people, equipment or both. The magnitude of the arcing fault is only 43-57% of a bolted fault, so traditional overcurrent protection may not detect and clear the fault before the full impact of the arc develops and causes damage or injury.

To gain a better understanding of how to deal with an arcing fault, let’s consider what the contributing

variables are and the corresponding incident energy calculations that help categorize them. A complete discussion on arc flash calculations can be found in IEEE 1584 – “Guide for Performing Arc Flash Hazard Calculations”. [1]

## What Variables Contribute To An Arcing fault?

There are many items that can initiate an arcing fault. Rather than focusing on what the ignition sources can be, the system factors associated with how we quantify the arcing fault will be considered. With the benefit of this information, mitigation techniques can be outlined and categorized. Figure 1 illustrates some of the basic parameters that factor into an incident energy calculation that in turn leads to the Hazard Risk Category labeling.

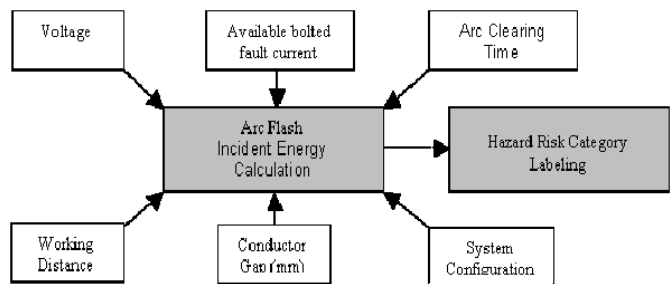

Figure 1 – Incident Energy Calculation

Clearly, there are many variables that factor into the incident energy calculation. Some are specific to equipment types while others are tied to system parameters or maintenance practices. Each variable plays a particular role in how we categorize the arc flash hazard and each is briefly touched upon below:

- Voltage – The ability to sustain the arc. Arcing faults are generally limited to systems where the bus voltage is greater than 120V.
- Available bolted fault current - The punch behind the arc fault magnitude. Recall that the magnitude of an arcing fault is approximately 43-57% of the bolted fault value. This implies that systems with significant bolted fault currents will have elevated arcing current levels. The reverse is also true; lower bolted fault levels will lead to lower arcing fault energies. Items such as system impedance, transformer sizing, utility, motor, and generator contributions establish the available fault current.
- Arc clearing time - This includes detection & protective device operating time. It is tied to the operating characteristics of a specific protective

# GE Arc Vault™ Protection System

device for a given level of arcing current. Reducing clearing time is critical to reducing the impacts of arcing fault.

- **Conductor gap distance.** Defines the distance between conductors that an arc must cross. Varies by equipment type and manufacturer, but is fixed for a specific piece of equipment.
- **Working distance.** The distance from a potential arc source to a worker's face and chest. Typically assumed to be 18". Items such as remote monitoring and racking can be implemented to remove the operator from the flash zone to for routine maintenance tasks.
- **System configuration.** Solidly grounded, resistance grounded, etc. This category also takes into consideration whether the arc environment is enclosed or open.

Given a basic understanding of what variables contribute to an incident energy calculation, the next logical question is to ask what the engineer can do to reduce this energy or exposure to it? Since energy is a function of current, voltage and time, there are several strategies that can be explored:

- Reducing the available fault current
- Reducing the arcing time
- Transferring the energy into a less damaging form or place quicker than it could otherwise be interrupted. This is the basis of the GE Arc Vault™ Protection System

The paragraphs that follow will highlight several of these strategies.

## Methods of Limiting Incident Energy and The Exposure to Arcing Faults

Over the years, different methods to limit arc flash exposure and incident energy have been introduced and can be divided into two general categories; active and passive. Passive mitigation is defined to be an equipment option or type that either contains and re-directs the arc blast or helps to eliminate the potential of a flash event (i.e. insulated main bus). This type of mitigation does not require any actions or settings by an operator to implement. On the opposite end of the spectrum is active mitigation. Active mitigation takes a pro-active approach to reducing both incident energy and the exposure to arcing faults through the active use of technology, design and

maintenance practices. The simplest example of active mitigation is to not approach or work on live electrical equipment. Figure 2 contains a list of passive and active items.

Passive	Active
<b>Reduce exposure with equipment options</b> <ul style="list-style-type: none"> <li>• Insulated/ isolated bus</li> <li>• IR scanning windows</li> <li>• Closed door drawout of breakers</li> <li>• Side section barriers</li> <li>• Hinged vs. bolted doors</li> <li>• Heaters</li> </ul>	<b>Technology to reduce arcing time &amp; incident energy</b> <ul style="list-style-type: none"> <li>• Arc Vault™</li> <li>• ZSI of instantaneous</li> <li>• Crow bar</li> <li>• Bus differential (87B)</li> <li>• Maint settings (RELT)</li> <li>• Current limiting devices</li> </ul>
<b>Reduce exposure with equipment types</b> <ul style="list-style-type: none"> <li>• Arc resistant structures</li> </ul>	<b>Design practices to reduce arcing time &amp; incident energy</b> <ul style="list-style-type: none"> <li>• Consider fault currents</li> <li>• Transformer sizes</li> <li>• Grounding</li> <li>• Single or double ended</li> </ul>
<b>Others?</b>	<b>Reduce exposure via maintenance practices</b> <ul style="list-style-type: none"> <li>• Follow NFPA 70E</li> <li>• No live maintenance</li> <li>• Remote switching</li> <li>• Remote racking</li> <li>• Remote monitoring</li> <li>• Remove contaminants</li> <li>• Training &amp; labeling</li> <li>• Use of proper PPE</li> </ul>

Figure 2 – Arc Flash Mitigation Techniques

One clear distinction between the passive and active methods is that the passive method does nothing in the way of detecting or removing an arcing fault. It is focused solely on containing the arc blast or eliminating a potential starting point for an arc flash via equipment options. One should not employ passive techniques without thinking through items such as thermal scanning. Equipment options like insulated main bus and isolated phase bus are good preventative measures, however they present an issue to performing thermal scans of items other than load connections.

The active methods seek to attack on both fronts; incident energy reduction and reduced exposure. The newest technology on the active side is the GE Arc Vault™ Protection System. To highlight the application of the Arc Vault™, the following

# GE Arc Vault™ Protection System

paragraphs will contrast the Arc Vault™ vs. the passive, arc resistant structure. The remaining items are listed for reference and will not be covered in detail

## LV Metal Enclosed Switchgear

Typical LV Metal Enclosed Switchgear is designed and tested to withstand the mechanical forces associated with bolted faults (non arcing). It is not constructed to contain and re-direct the arc blast away from the operator. The standard construction must be able to withstand (carry) the bolted fault current from the line side of the main breaker through the load terminations on the feeders and is short circuit tested to ensure compliance with the applicable ANSI standards. During a short circuit interruption, there may be some out gassing of arc by-products from the breaker, but not to the violent extent of the arcing fault.

An arc resistant line of LV switchgear is also designed to withstand and interrupt a bolted fault, however it provides a level of protection to arcing faults that is not incorporated in the standard design. Arc resistant structures have been around for 30 plus years and can trace their roots back to IEC standards. In North America, this type of structure is tested & categorized to ANSI C37.20.7, refer to figure 3. The word arc resistant implies that no arc fault emissions/blast will occur in the areas described by each category. For example, with a properly installed Type 1 design, an operator could approach the front of a switchgear lineup and not be exposed to the arc blast if an arcing fault were to occur. If the operator were standing to the side of this design, the same protection would not be provided.

ANSI Type	Comments – arc resistant construction applies to
Type 1	The front only.
Type 1C	The front, as well as between compartments of the same or adjacent cells.
Type 2	The front, back and sides of the enclosure.
Type 2C	The front, back, sides as well as between compartments of the same or adjacent cells.

Figure 3 – Arc Resistant Structure Categories

To function properly, arc resistant structures have several distinguishing characteristics not found in traditional gear.

- Reinforced construction is used to withstand & contain the pressure wave. Front & rear doors, section barriers, etc may be reinforced and gasketed depending on the ANSI type.
- Exhaust chambers are employed within the structure to safely re-direct the arcing fault by products away from the operator and toward the vent flaps.
- Vent flaps that open due to increased pressure vent the arc blast. Typically out the top.
- Figures 4 illustrates the re-direction and venting of the arcing fault.

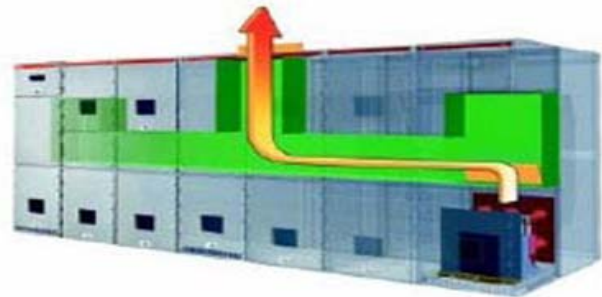

Figure 4 – Illustration of Arc Resistant Venting

## Considerations – Arc Resistant Structures

The arc resistant structure does an excellent job of protecting the operator from an arc flash event, however it is not a panacea. As noted earlier, this passive technique seeks only to contain the arc blast, but nothing to reduce incident energy or remove the arcing fault, which can result in substantial equipment damage and downtime. Like all products, the application of arc resistant structures requires consideration and awareness of items that are specific to the construction. Several items are listed below for consideration.

### Equipment Damage / Downtime

What type of downtime will the owner experience for an arcing fault? It is reasonable to expect some structural damage that will require repair as a result of the arc blast. Bus, doors, barriers are likely candidates for repair. Are there other mitigations methods that can provide operator protection and help reduce equipment damage at the same time?

# GE Arc Vault™ Protection System

## Maintenance/ Approaching Live Equipment

The protection afforded by the arc resistant structure can be negated if a door is not properly secured or if the maintenance task requires the operator to open a door or compartment. What are the impacts to operator safety, maintenance practices, etc?

## Installation Considerations

Where does the effluent go when it is vented from the structure? Does the room size need to be increased? Does a restricted area need to be developed and labeled? Is placement of the structure limited to certain areas?

## Cost & Size Impacts

What are the cost & size impacts associated with the structure itself? Does the room size need to be increased?

## Existing Equipment

The arc resistant structure cannot be retrofit onto existing equipment.

The comments above are not meant to disparage the arc resistant design. Rather they are meant to highlight that with all products there are application considerations that must be taken into account. Items such as live maintenance, equipment damage, room size and venting are real concerns that need to be thought through and contrasted against other mitigation techniques.

## How is the GE Arc Vault™ Different?

The GE Arc Vault™ is an active mitigation technique and aspires to the same basic goal as the arc resistant structure; to protect the operator. However it does so in a much different fashion than arc resistant structures. Instead of containing and venting the arc flash effluent, it seeks to limit incident energy via the identification and removal of an arcing fault before it escalates into the signature arc blast and elevated hazard risk categories. The result is a solution that addresses three key areas:

- Reduction of the arc flash hazard.
- Improved equipment uptime/ reduced damage.
- Ability to retrofit existing switchgear

The architecture for the absorber is depicted in figure 5 and consists of a current sensor, a

parallel-connected containment dome, light sensors and a logic controller.

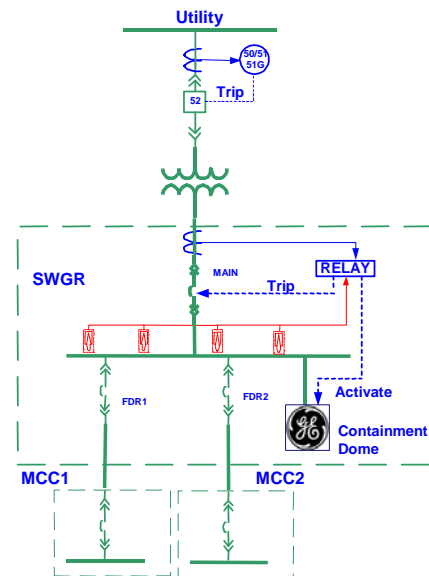

Figure 5 - Architecture

The current sensor looks for the signature of an arcing fault while the light sensor looks for a simultaneous optical event. The combination of the two is fed into a logic controller which makes the decision on whether to engage the absorber or not.

At this point you may be thinking that GE has created a crow bar. Rest assured, we have not, please read on.

The Arc Absorber has no moving parts and makes use of a plasma gun and containment chamber. When the logic controller activates the absorber, two simultaneous actions take place. A trip signal is sent to the main breaker and the absorber is activated. When activated, the absorber triggers the plasma gun to break down the dielectric in the air gap within the absorption chamber. The resulting arc creates a lower impedance, phase-to-phase path than the "in equipment" arcing fault presents to the system. This low impedance path is not a bolted fault and in turn re-directs/ absorbs fault current originally flowing towards the arcing fault within the controlled environment of the containment chamber. The arc within the containment chamber is then safely cooled and vented. The open air or "in equipment" arc is extinguished as the bus voltage decreases due to the low impedance path within the absorber. The time required to quench the open-air arc is 8ms. The event is brought to conclusion when

# GE Arc Vault™ Protection System

the main protective device opens and eliminates current flow within the absorption chamber.

It is important to note that since this system works at arcing fault current levels, as opposed to bolted fault levels, there is a significant energy reduction. The result is 63% less energy, and considerably less stress on the system, when compared to crowbar type systems. This energy reduction applies to not just the local switchgear, but also to other system components like transformers.

The prototype of the Arc Vault™ containment dome is about the size of an 800AF breaker and is rated for applications of 100 kA at 480V.

The GE Arc Vault™ protection system will contain an arc fault in less than 8ms with the circuit breaker compartment doors open during operation and maintenance. The incident energy in accordance with IEEE 1584 at 24" from the arc event will be less than 1.2cal/cm<sup>2</sup>, which is equivalent to HRC0, for a 480V HRG system with available fault currents up to 100kA.

In addition to incident energy/ HRC reduction, eliminating the arcing fault, reducing equipment damage, and eliminating arcing fault effluent. The Arc Vault™ offers the following benefits not found in traditional arc resistant structures:

## New and retrofit applications

The Arc Vault™ can be implemented in new or existing LV switchgear platforms while the arc resistant structure is tied to new installations only.

## Reuse

The Arc Vault™ will be reusable, with minor maintenance or parts replacement, depending on the available fault currents it is applied on. Arc resistant structures will in all likelihood sustain some form of damage and require repair to place it back into service.

## Maintenance Activities

The Arc Vault™ does not depend on doors being closed to provide arc flash protection. Hence the established Hazard Risk Category does not change whether the doors are open or closed.

## No Effluent Ventilation

No need for increased ceiling heights or the creation of restricted areas to avoid potential exposure to redirected effluent.

## Conclusion

There are many techniques that can be employed to help mitigate the damaging effects of arcing faults. This article has introduced the concept of the Arc Vault™ as a feasible alternative to arc resistant structures. The Arc Vault™ can at minimum offer the same or similar Hazard Risk Category (HRC) protection as the arc resistant structure but far exceeds the structure in the areas of equipment protection, uptime, re-use and others. GE presented this concept on the arc absorber to the [IEEE Petroleum and Chemical Conference Technical Conference](#) in September of 2009.

## References

- [1] IEEE 1584 – guide for performing arc flash hazard calculations
- [2] IEEE C37.20.7: "Guide for Testing Medium Voltage Metal Enclosed Switchgear for Internal Arcing Faults."