



**GE Capacitor**

# **GEMACTIVE**

**Active Filter System**





## GE GEMActive

- Dynamic current injection for harmonic cancellation and power factor correction
- Reduces harmonics for IEEE 519 (1992) standard compliance
- Decreases harmonic related overheating of cables, switchgear and transformers
- Reduces downtime caused by nuisance thermal tripping of protective devices
- Increases electrical network reliability and reduces operating costs
- Compensates each phase independently
- UL and CSA approved
- Parallel connection allows for easy retrofit and installation of multiple units for large networks
- Filters to the 50th harmonic
- Filters entire network or specific loads depending on installation point
- Response to load fluctuations begins in 40 microseconds with 8 milliseconds for full response to step load changes
- IGBT based power electronic technology
- 50, 100 and 300A models for 208 to 480V, 50/60 Hz three phase networks

GE GEMActive reduces problematic harmonic levels and provides instantaneous power factor correction. Cost savings result from reduced downtime and maintenance. In addition, over-sizing of distribution equipment to provide for harmonics and poor power factor can be avoided. GE GEMActive dynamically corrects power quality by providing: Active Harmonic Filtration, Resonance Prevention, Power Factor Correction and Dynamic VAR Compensation

### The Harmonic Problem

Although power electronic loads and devices which have rapid and frequent load variations have become abundant due to their many process control related benefits, they have one major drawback in common: they produce harmonics. Harmonics may disrupt other loads and increase operating costs and lower the reliability of the electrical network. The current waveform required by power electronic loads is quite different than the sinusoidal voltage delivered by the utility. This 'non-linear' current draw (Figure 1) results in the creation of harmonics.

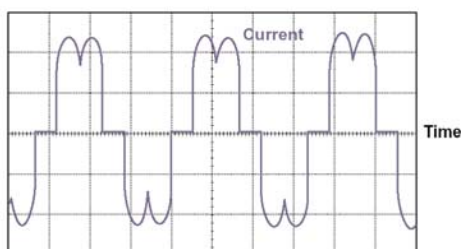
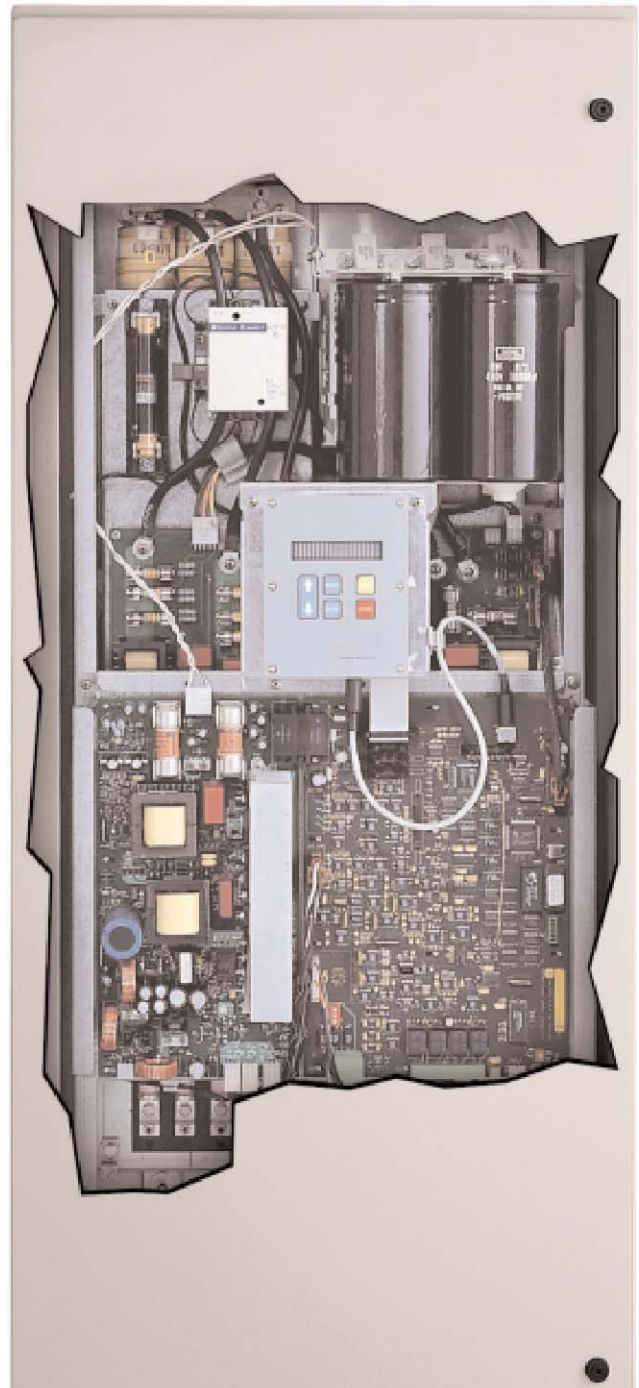

Figure 1: Non-linear current

Symptoms of problematic harmonic levels include overheating of motors, drives, cables, thermal tripping of protective devices and logic faults of digital devices all of which can result in downtime. In addition the life span of many devices may be reduced by overheating. Furthermore, by reducing harmonic levels, the need to oversize transformers and cables to account for harmonic heating effects is lessened.

With this in mind, the IEEE 519-1992 recommended practice establishes limits on current distortion that individual facilities can feed back on to the utility grid. Many utilities enforce these limits and with the decrease in capital spending due to deregulation of the industry, many more utilities are expected to start to enforce these limits.



## Active Harmonic Filtering with GEMActive

The GE GEMActive cancels harmonics by dynamically injecting out of phase harmonic current. GEMActive installation will allow for compliance with IEEE 519 – 1992 recommended harmonic limits. Reduced harmonic levels results in improved electrical network reliability and reduced operating costs. Nuisance tripping of protective devices and nuisance clearing of fuses due to harmonic heating effects is greatly reduced.

Overheating of motors, transformers, switchgear and cables is also reduced which increases their life expectancy and reduces maintenance costs. For new installations, over-sizing of distribution equipment to reduce harmonic susceptibility can be reconsidered.

GEMActive reduces current distortion that, in turn, reduces voltage distortion. Unlike passive devices, GEMActive is easy to install and cannot be overloaded. When required harmonic compensation exceeds capacity, GEMActive will simply supply its maximum continuously. Multiple GEMActive units can be connected in parallel to increase compensation.

Closed-loop control allows for high accuracy and self-adaptive harmonic control. GEMActive determines the harmonic compensation required by using current transformers to measure the network current. The GEMActive control logic removes the fundamental frequency component (50 or 60 Hz) from this waveform. The remaining waveform is then inverted and GEMActive fires its IGBTs to inject this waveform (Figure 2) on to the network to compensate for the harmonics. The result is a waveform with greatly reduced harmonic content as seen by the upstream electrical system (Figure 3).

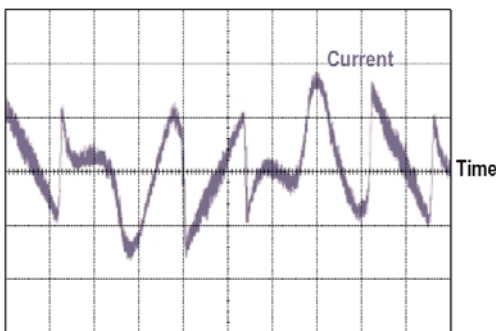

Figure 2: GEMActive Injection Current

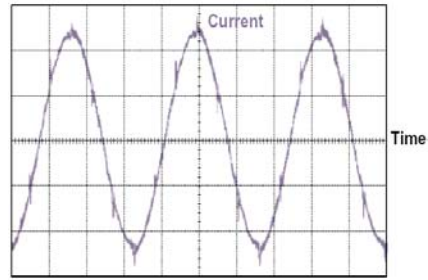

Figure 3 Corrected current waveform

## The Resonance Problem

The interconnection of a large variety of devices on today's electrical networks can create resonant conditions which magnify harmonic currents (Figure 4). Resonance can cause serious problems such as excessive voltage distortion, nuisance fuse and circuit breaker operation, overvoltage tripping of drives, premature capacitor breakdown and insulation breakdown within motors, transformers and conductors.

## GEMActive Eliminates Resonance

General Electric GEMActive cancels harmonic current on the network to eliminate resonance conditions. By dynamically removing harmonics from the network no energy is present at the resonant frequency. The point of installation of GEMActive on the electrical network determines where the harmonic cancellation takes place.

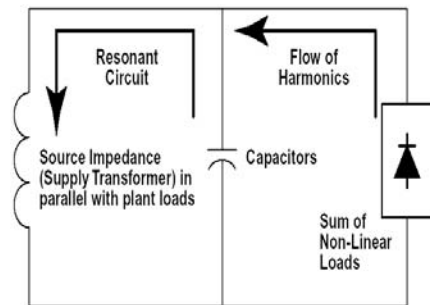

Figure 4 Circuit formed from Capacitor in Parallel with Source Impedance (Supply Transformer)

## Power Factor Correction with GEMActive

Poor power factor results in increased peak currents that reduce system capacity and, in most cases, cause a utility imposed penalty. GEMActive is able to solely correct power factor, or, operate in a dual mode whereby current is injected to reduce harmonics and any excess current capacity is used to improve the power factor. Power factor correction is achieved by injecting current at the fundamental frequency (60/50 Hz). GEMActive is able to correct for either a leading or lagging power factor. The result is a reduction in peak currents which frees system capacity and eliminates utility imposed power factor penalties.

## Dynamic VAR Compensation by GEMActive

Large inductive inrush currents typically cause voltage sags that result in reduced productivity, poor process quality and possible downtime due to undervoltage tripping of devices.

The General Electric GEMActive is able to inject peak current at two and a half times its rms current rating for one cycle. For many applications this level of compensation eliminates visible flicker and improves voltage regulation resulting in better productivity and quality.

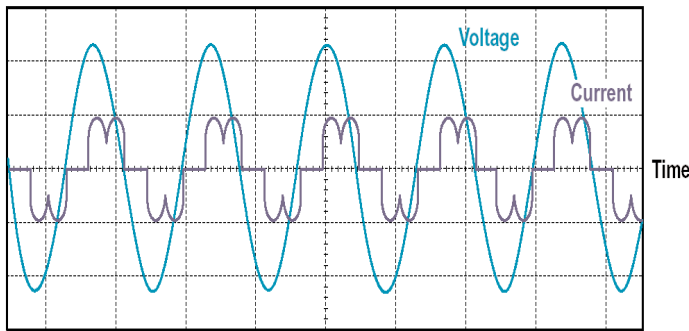

Figure 5: Non-linear current waveform with poor power factor

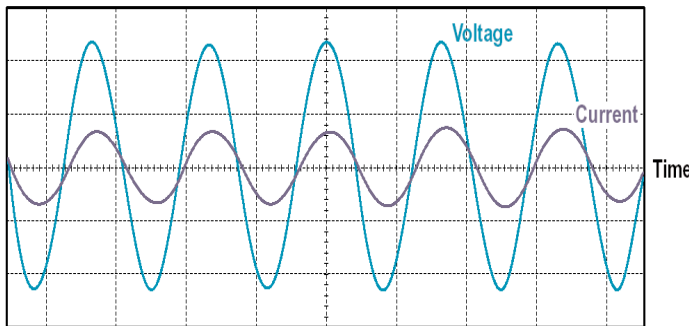

Figure 6: Corrected Current waveform with improved power factor and reduced harmonic content after GEMActive Installation

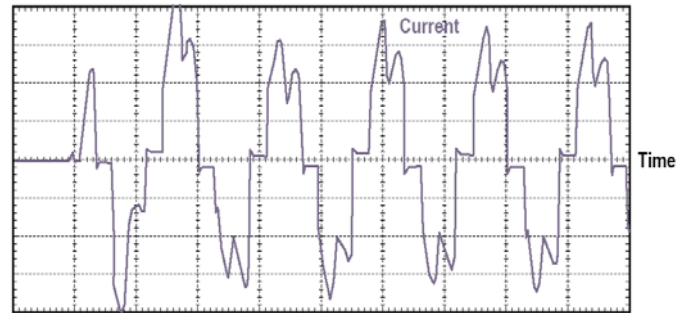

Figure 7: Inrush Current without GE GEMActive

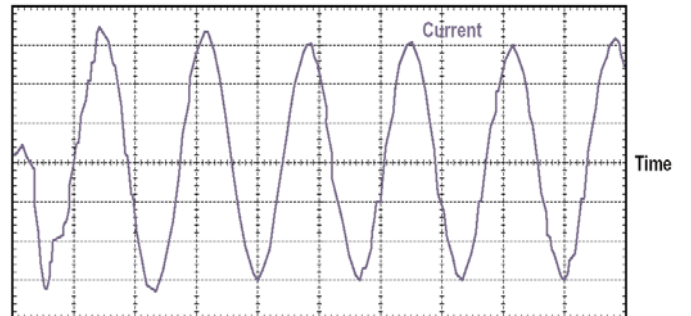
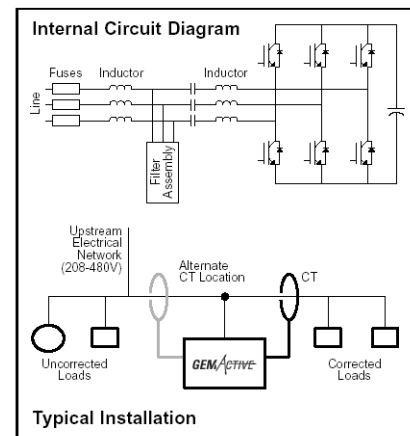

Figure 8: Inrush Current with GE GEMActive



## GEMActive Sizing

A harmonic study is not required to select the size of the GEMActive installation. This is because when GEMActive is installed it becomes a lower impedance path for harmonics than the existing power supply. For sizing, please contact General Electric. To expedite the product selection process, please have a single line diagram and/or details of the application including sizes of transformers, non-linear and linear loads, and any existing filters and capacitors.

## Product Selection

GEMActive, 208-480 V Three Phase, 50/60 Hz Models

Current Rating	Enclosure Type	Part Number 240/480V	Enclosure		Exterior Dimensions (HxWxD (in.))	Weight (lbs.)
			Type	Cable Entry		
50	NEMA 1	37GA050FG	Wall Mount	Bottom	52x21x19	250
100	NEMA 1	37GA100FG	Wall Mount	Bottom	69x21x19	350
300	NEMA 1	37GA300FG	Floor Standing	Top	75x33x20	775

Current Rating	Enclosure Type	600V
50	NEMA 1	37GA050HG
100	NEMA 1	37GA100HG
300	NEMA 1	37GA300HG

GE offers other power quality products. For additional information on line & load reactors, high voltage capacitor equipment and harmonic solutions, contact your GE Industrial Systems office or the address below.



---

**GE Capacitor**

*GE Capacitor and Arrester  
381 Broadway, Ft. Edward, NY 12828  
[www.geindustrial.com](http://www.geindustrial.com), choose Products > Capacitor  
©2003 General Electric Company*